



CHAPTER 2

TRANSMITTER AND RECEIVER SYSTEMS

<u>Paragraph</u>	<u>Subject</u>	<u>Page</u>
2.1	Radio Frequency Standards for Telemetry	2-1
2.2	Definitions	2-1
2.3	Bands	2-2
2.4	Telemetry Transmitter Systems	2-4
2.5	Telemetry Receiver Systems	2-15

REFERENCES

LIST OF FIGURES

Figure 2-1.	FQPSK-JR baseband signal generator.....	2-6
Figure 2-2.	Basic SOQPSK.	2-8
Figure 2-3.	SOQPSK transmitter.....	2-10
Figure 2-4.	Conceptual CPM modulator.	2-11
Figure 2-5.	Continuous single sideband phase noise power spectral density.....	2-13

LIST OF TABLES

TABLE 2-1.	TELEMETRY FREQUENCY ALLOCATIONS.....	2-2
TABLE 2-2.	FQPSK-JR SHAPING FILTER DEFINITION.....	2-7
TABLE 2-3.	FQSPK-B AND FQSPK-JR PHASE MAP	2-8
TABLE 2-4.	SOQPSK-TG PARAMETERS	2-10
TABLE 2-5.	SOQPSK PRE-CODING TABLE FOR IRIG-106 COMPATIBILITY.....	2-11
TABLE 2-6.	DIBIT TO IMPULSE AREA MAPPING	2-12
TABLE 2-7.	STANDARD RECEIVER INTERMEDIATE FREQUENCY (IF) BANDWIDTHS.....	2-16

This page intentionally left blank.

CHAPTER 2

TRANSMITTER AND RECEIVER SYSTEMS

2.1 Radio Frequency Standards for Telemetry

These standards provide the criteria to determine equipment and frequency use requirements and are intended to ensure efficient and interference-free use of the radio frequency spectrum. These standards also provide a common framework for sharing data and providing support for test operations between ranges. The radio frequency spectrum is a limited natural resource; therefore, efficient use of available spectrum is mandatory. In addition, susceptibility to interference must be minimized. Systems not conforming to these standards require justification upon application for frequency allocation, and the use of such systems is highly discouraged. The standards contained herein are derived from the National Telecommunications and Information Administration's (NTIA) Manual of Regulations and Procedures for Federal Radio Frequency Management; see <http://www.ntia.doc.gov/osmhome/redbook/redbook.html>.

2.2 Definitions

Allocation (of a Frequency Band): Entry of a frequency band into the Table of Frequency Allocations¹ for use by one or more radio communication services or the radio astronomy service under specified conditions.

Assignment of a Radio Frequency (RF) or Radio Frequency Channel (RFC): Authorization given by an administration, for a radio station to use a radio frequency or radio frequency channel under specified conditions.

Authorization: Permission to use a RF or RFC channel under specified conditions.

Occupied Bandwidth: The width of a frequency band such that below the lower and above the upper frequency limits, the mean powers emitted are each equal to a specified percentage of the total mean power of a given emission. Unless otherwise specified by the International Telecommunication Union (ITU) for the appropriate class of emission, the specified percentage shall be 0.5 percent. The occupied bandwidth is also called the 99-percent power bandwidth in this document.

Primary Service: A service that has full rights in a band of frequencies and can claim protection from harmful interference from other services.

Secondary Service: Service that can be obtained on a noninterference operation basis with primary service users. Stations of a secondary service shall not cause harmful interference to stations of a primary service and cannot claim protection from interference from stations of a

¹ The definitions of the radio services that can be operated within certain frequency bands contained in the radio regulations as agreed to by the member nations of the International Telecommunications Union. This table is maintained in the United States by the Federal Communications Commission and the NTIA.

primary service; however, they can claim protection from harmful interference from other secondary stations to which frequencies were assigned at a later date.

2.3 Bands

The bands used for telemetry are described unofficially below. Additional detail can be seen at Table 2-1.

Lower L-band	1435 - 1535 MHz	Lower C-band	4400 - 4940 MHz
Lower S-band	2200 - 2290 MHz	Middle C-band	5091 - 5150 MHz
Upper S-band	2310 - 2395 MHz	Upper C-band	5925 - 6700 MHz

The 1755 to 1850 MHz band (unofficially called “upper L-band”) can also be used for telemetry at many test ranges although it is not explicitly listed as a telemetry band in the NTIA Table of Allocations. The mobile service is a primary service in the 1755 to 1850 MHz band and telemetry is a part of the mobile service. Since the 1755-1850 MHz band is not considered a standard telemetry band per this document, potential users must coordinate, in advance, with the individual range(s) and ensure use of this band can be supported at the subject range and that it will meet their technical requirements. While these band designations are common in telemetry parlance, they may have no specific meaning to anyone else. Telemetry assignments are made for testing² manned and unmanned aircraft, for missiles, space, land, and sea test vehicles, and for rocket sleds and systems carried on such sleds. Telemetry assignments are also made for testing major components of the aforementioned systems.

TABLE 2-1. TELEMETRY FREQUENCY ALLOCATIONS

Frequency Range (MHz)	Unofficial Designation	Comments	Refer to:
1435-1525	Lower L-band	Telemetry primary service (part of mobile service) in USA	2.3.1
1525-1535	Lower L-band	Mobile satellite service (MSS) primary service, telemetry secondary service in USA	2.3.1
2200-2290	Lower S-band	Telemetry co-primary service in USA	2.3.2
2310-2360	Upper S-band	Wireless Communications Service (WCS) and broadcasting-satellite (sound) service (BSS) primary services, telemetry secondary service in USA	2.3.3
2360-2395	Upper S-band	Telemetry primary service in USA	2.3.3
4400-4940	Lower C-band	See Paragraph 2.3.4	2.3.4
5091-5150	Middle C-band	See Paragraph 2.3.5	2.3.5
5925-6700	Upper C-band	See Paragraph 2.3.6	2.3.6

²A telemetry system as defined here is not critical to the operational (tactical) function of the system.

2.3.1 Allocation of the Lower-L Band (1435 to 1535 MHz). This band is allocated in the United States of America and its possessions for government and nongovernmental aeronautical telemetry use on a shared basis. The Aerospace and Flight Test Radio Coordinating Council (AFTRCC) coordinates the non-governmental use of this band. The frequencies in this range will be assigned for aeronautical telemetry and associated remote-control operations³ for testing of manned or unmanned aircraft, missiles, rocket sleds, and other vehicles or their major components. Authorized usage includes telemetry associated with launching and reentry into the earth's atmosphere as well as any incidental orbiting prior to reentry of manned or unmanned vehicles undergoing flight tests. The following frequencies are shared with flight telemetering mobile stations: 1444.5, 1453.5, 1501.5, 1515.5, 1524.5, and 1525.5 MHz.

2.3.1.1 1435 to 1525 MHz. This frequency range is allocated for the exclusive use of aeronautical telemetry in the United States of America.

2.3.1.2 1525 to 1530 MHz. The 1525 to 1530 MHz band was reallocated at the 1992 World Administrative Radio Conference (WARC-92). The mobile-satellite service is now a primary service in this band. The mobile service, which includes aeronautical telemetry, is now a secondary service in this band.

2.3.1.3 1530 to 1535 MHz. The maritime mobile-satellite service is a primary service in the frequency band from 1530 to 1535 MHz.⁴ The mobile service (including aeronautical telemetry) is a secondary service in this band.

2.3.2 Allocation of the lower-S Band (2200 to 2300 MHz). No provision is made in this band for the flight-testing of manned aircraft.

2.3.2.1 2200 to 2290 MHz. These frequencies are shared equally by the United States Government's fixed, mobile, space research, space operation, and the Earth Exploration Satellite Services (EESS), and include telemetry associated with launch vehicles, missiles, upper atmosphere research rockets, and space vehicles regardless of their trajectories.

2.3.2.2 2290 to 2300 MHz. Allocations in this range are for the space research service (deep space only) on a shared basis with the fixed and mobile (except aeronautical mobile) services.

2.3.3 Allocation of the Upper S Band (2310 to 2395 MHz). This band is allocated to the fixed, mobile, radiolocation, and broadcasting-satellite services in the United States of America. Government and nongovernmental telemetry users share this band in a manner similar to that of the L band. Telemetry assignments are made for flight-testing of manned or unmanned aircraft, missiles, space vehicles, or their major components.

2.3.3.1 2310 to 2360 MHz. These frequencies have been reallocated and were auctioned by the Federal Communications Commission in April 1997. The Wireless Communications Service is the primary service in the frequencies 2305-2320 MHz and 2345-2360 MHz. The broadcasting-satellite (sound) service is the primary service in the 2320-2345 MHz band. In the

³The word used for remote control operations in this band is *telecommand*.

⁴ Reallocated as of 1 January 1990.

band 2320-2345 MHz, the mobile and radiolocation services are allocated on a primary basis until a broadcasting-satellite (sound) service has been brought into use in such a manner as to affect or be affected by the mobile and radiolocation services in those service areas

2.3.3.2 2360 to 2395 MHz. The Mobile Service (including aeronautical telemetry) is a primary service in this band.

2.3.4 Allocation of the Lower C-band (4400-4940 MHz). Telemetry is an operation which is currently allowed under the mobile service allocation.

2.3.5 Allocation of the Middle C-band (5091-5150 MHz). The process of incorporating aeronautical telemetry operations into the NTIA Table of Frequency Allocations for this band has been initiated but not yet completed.

2.3.6 Allocation of the Upper C-band (5925-6700 MHz). This band is not currently allocated as a Government band. The process of incorporating federal government use of aeronautical telemetry operations into the NTIA Table of Frequency Allocations for this band has been initiated but not yet completed.

2.4 Telemetry Transmitter Systems

Telemetry requirements for air, space, and ground systems are accommodated in the appropriate bands as described in paragraph [2.3](#).

2.4.1 Center Frequency Tolerance. Unless otherwise dictated by a particular application, the frequency tolerance for a telemetry transmitter shall be ± 0.002 percent of the transmitter's assigned center frequency. Transmitter designs shall control transient frequency errors associated with startup and power interruptions. During the first second after turn-on, the transmitter output frequency shall be within the occupied bandwidth of the modulated signal at any time when the transmitter output power exceeds -25 dBm. Between 1 and 5 seconds after initial turn-on, the transmitter frequency shall remain within twice the specified limits for the assigned radio frequency. After 5 seconds, the standard frequency tolerance is applicable for any and all operations where the transmitter power output is -25 dBm or greater (or produces a field strength greater than 320 $\mu\text{V}/\text{meter}$ at a distance of 30 meters from the transmitting antenna in any direction). Specific uses may dictate tolerances more stringent than those stated.

2.4.2 Output Power. Emitted power levels shall always be limited to the minimum required for the application. The output power shall not exceed 25 watts⁵. The effective isotropic radiated power (EIRP) shall not exceed 25 watts⁵.

2.4.3 Modulation. The traditional modulation methods for aeronautical telemetry are frequency modulation and phase modulation. Pulse code modulation (PCM)/frequency modulation (FM) has been the most popular telemetry modulation since around 1970. The PCM/FM method could also be called filtered continuous phase frequency shift keying

⁵ An exemption from this EIRP limit will be considered; however, systems with EIRP levels greater than 25 watts will be considered nonstandard systems and will require additional coordination with affected test ranges.

(CPFSK). The RF signal is typically generated by filtering the baseband non-return-to-zero-level (NRZ-L) signal and then frequency modulating a voltage-controlled oscillator (VCO). The optimum peak deviation is 0.35 times the bit rate and a good choice for a premodulation filter is a multi-pole linear phase filter with bandwidth equal to 0.7 times the bit rate. Frequency and phase modulation have a variety of desirable features but may not provide the required bandwidth efficiency, especially for higher bit rates. When better bandwidth efficiency is required, the standard methods for digital signal transmission are the Feher patented quadrature phase shift keying (FQPSK-B and FQPSK-JR), the shaped offset quadrature phase shift keying (SOQPSK-TG), and the Advanced Range Telemetry (ARTM) continuous phase modulation (CPM). Each of these methods offer constant, or nearly constant, envelope characteristics and are compatible with non-linear amplifiers with minimal spectral regrowth and minimal degradation of detection efficiency. The first three methods (FQPSK-B, FQPSK-JR, and SOQPSK-TG) are interoperable and require the use of the differential encoder described in paragraph 2.4.3.1.1 below. Additional information on this differential encoder is contained in Appendix M. All of these bandwidth-efficient modulation methods require the data to be randomized. Additional characteristics of these modulation methods are discussed in the following paragraphs and in section 7 of Appendix A.

2.4.3.1 Characteristics of FQPSK-B. FQPSK-B is described in the Digcom Inc. publication, “*FQPSK-B, Revision A1, Digcom-Feher Patented Technology Transfer Document, January 15, 1999.*” This document can be obtained under a license from:

Digcom Inc.
44685 Country Club Drive
El Macero, CA 95618
Telephone: 530-753-0738
FAX: 530-753-1788

2.4.3.1.1 Differential Encoding. Differential encoding shall be provided for FQPSK-B, FQPSK-JR, and SOQPSK-TG and shall be consistent with the following definitions:

The NRZ-L data bit sequence $\{b_n\}$ is sampled periodically by the transmitter at time instants:

$$t = nT_b \qquad n = 0, 1, 2, \dots$$

Where T_b is the NRZ-L bit period.

Using the bit index values n as references to the beginning of symbol periods, the

differential encoder alternately assembles I-channel and Q-channel symbols to form the following sequences:

$$I_2, I_4, I_6, \dots$$

and

$$Q_3, Q_5, Q_7, \dots$$

according to the following rules:

$$I_{2n} = b_{2n} \oplus \overline{Q_{(2n-1)}} \quad n > 0 \quad (2-1)$$

$$Q_{(2n+1)} = b_{(2n+1)} \oplus I_{2n} \quad n > 0 \quad (2-2)$$

Where \oplus denotes the exclusive-or operator, and the bar above a variable indicates the ‘not’ or inversion operator. Q channel symbols are offset (delayed) relative to I-channel symbols by one bit period.

2.4.3.1.2 Characteristics of FQPSK-JR. FQPSK-JR is a cross-correlated, constant envelope, spectrum shaped variant of FQPSK. It assumes a quadrature modulator architecture and synchronous digital synthesis of the I and Q-channel modulating signals as outlined in Figure2-1.

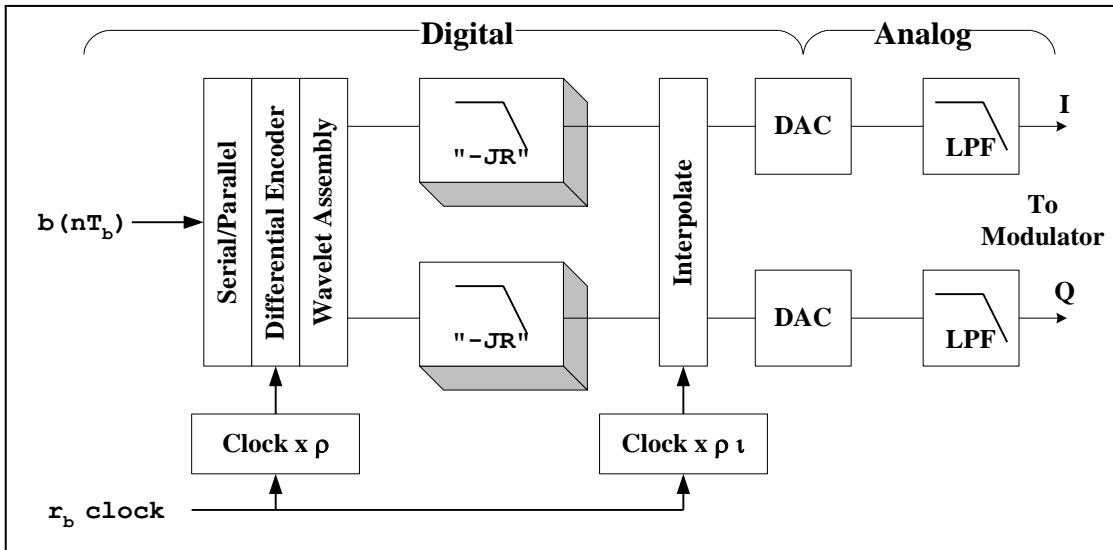

Figure 2-1. FQPSK-JR baseband signal generator.

FQPSK-JR utilizes the time domain wavelet functions defined in United States Patent 4567602, Correlated Signal Processor, with two exceptions. The transition functions used in the cited patent,

$$G(t) = \begin{cases} \pm \left[1 - K \cos^2\left(\frac{\pi t}{T_s}\right) \right] \\ \pm \left[1 - K \sin^2\left(\frac{\pi t}{T_s}\right) \right] \end{cases} \tag{2-3}$$

$$K = 1 - A = 1 - \frac{\sqrt{2}}{2}$$

are replaced with the following transition functions:

$$G(t) = \begin{cases} \pm \sqrt{1 - A^2 \cos^2\left(\frac{\pi t}{T_s}\right)} \\ \pm \sqrt{1 - A^2 \sin^2\left(\frac{\pi t}{T_s}\right)} \end{cases} \tag{2-4}$$

$$A = \frac{\sqrt{2}}{2}$$

Where $T_s = 2/r_b$ is the symbol period. The digital “JR” spectrum-shaping filter used for each channel is a linear phase, finite impulse response (FIR) filter. The filter is defined in terms of its impulse response sequence $h(n)$ in Table 2-2 and assumes a fixed wavelet sample rate of $\rho = 6$ samples per symbol. The JR_{equiv} column is the aggregate response of the cascaded JR_a and JR_b filters actually used.

TABLE 2-2. FQPSK-JR SHAPING FILTER DEFINITION			
FILTER WEIGHT	JR_{equiv}	JR_a	JR_b
$h(0)$	-0.046875	2^{-2}	$-(2^{-3} + 2^{-4})$
$h(1)$	0.109375	$h(0)$	$(2^{-1} + 2^{-3})$
$h(2)$	0.265625	$h(0)$	$h(1)$
$h(3)$	$h(2)$	-	$h(0)$
$h(4)$	$h(1)$	-	-
$h(5)$	$h(0)$	-	-

Digital interpolation is used to increase sample rate, moving all alias images created by digital to analog conversion sufficiently far away from the fundamental signal frequency range that out-of-channel noise floors can be well controlled. The FQPSK-JR reference implementations currently utilize 4-stage Cascade-Integrator-Comb (CIC) interpolators with unity memory lag factor (see reference [11]). Interpolation ratio “i” is adjusted as a function of bit rate such that fixed cutoff frequency post-D/A anti-alias filters can be used to cover the entire range of required data rates.⁶

2.4.3.1.3 **Carrier Suppression.** The remnant carrier level shall be no greater than -30 dBc. Additional information of carrier suppression can be seen at section 7 of Appendix A.

2.4.3.1.4 **Quadrature Modulator Phase Map.** Table 2-3 lists the mapping from the input to the modulator (after differential encoding and FQPSK-B or FQPSK-JR wavelet assembly) to the carrier phase of the modulator output. The amplitudes in Table 2-3 are ± a, where “a” is a normalized amplitude.

TABLE 2-3. FQSPK-B AND FQSPK-JR PHASE MAP		
I CHANNEL	Q CHANNEL	RESULTANT CARRIER PHASE
a	a	45 degrees
-a	a	135 degrees
-a	-a	225 degrees
a	-a	315 degrees

2.4.3.2 **Characteristics of SOQPSK-TG.** SOQPSK is a family of constant envelope CPM waveforms defined by Mr. T. Hill (see references [2], [3], [4], and [5]). It is most simply described as a non-linear frequency modulation modeled as shown in Figure 2-2.

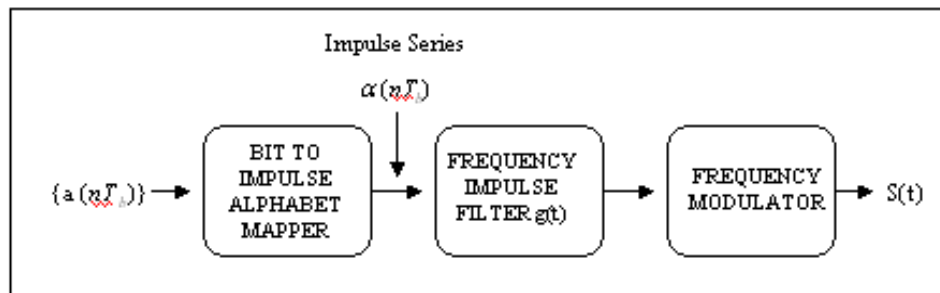

Figure 2-2. Basic SOQPSK.

⁶ The FQPSK-JR definition does not include a specific interpolation method and a post-D/A filter design. However, it is known that benchmark performance will be difficult to achieve if the combined effects of interpolation and anti-alias filter produce more than .04 dB excess attenuation at 0.0833 times the input sample rate and more than 1.6 dB of additional attenuation at 0.166 times the sample rate where the input sample rate is referred to the input of the interpolator assuming 6 samples per second.

The SOQPSK waveform family is uniquely defined in terms of impulse excitation of a *frequency* impulse shaping filter function $g(t)$:

$$g(t) = n(t)w(t) \quad (2-5)$$

Where

$$n(t) \equiv \left[\frac{A \cos \pi \theta_1(t)}{1 - 4\theta_1^2(t)} \right] \left[\frac{\sin \theta_2(t)}{\theta_2(t)} \right] \quad (2-6)$$

$$\theta_1(t) = \frac{\rho B t}{T_s}$$

$$\theta_2(t) = \frac{\pi B t}{T_s}$$

$$w(t) \equiv \begin{cases} 1, & \left| \frac{t}{T_s} \right| \leq T_1 \\ \frac{1}{2} \left[1 + \cos \left(\frac{\pi \left(\left| \frac{t}{T_s} \right| - T_1 \right)}{T_2} \right) \right], & T_1 < \left| \frac{t}{T_s} \right| \leq T_1 + T_2 \\ 0, & \left| \frac{t}{T_s} \right| > T_1 + T_2 \end{cases} \quad (2-7)$$

The function $n(t)$ is a modified spectral raised cosine filter of amplitude A , rolloff factor ρ , and an additional time scaling factor B . The function $w(t)$ is a time domain windowing function that limits the duration of $g(t)$. The amplitude scale factor A is chosen such that

$$\int_{-(T_1+T_2)T_s}^{(T_1+T_2)T_s} g(t) dt = \frac{\pi}{2} \quad (2-8)$$

Given a time series binary data sequence

$$\bar{a} = (\dots, a_{-2}, a_{-1}, a_0, a_1, a_2, \dots) \quad (2-9)$$

wherein the bits are represented by normalized antipodal amplitudes $\{+1, -1\}$, the ternary impulse series is formed with the following mapping rule (see also references [4] and [5]), ...

$$\alpha = (-1)^{i+1} \frac{a_{i-1}(a_i - a_{i-2})}{2} \quad (2-10)$$

... which forms a data sequence alphabet of three values $\{+1,0,-1\}$. It is important to note that this modulation definition does not establish an absolute relationship between the digital in-band inter-switch trunk signaling (dibits) of the binary data alphabet and transmitted phase as with conventional quadriphase OQPSK implementations. In order to achieve interoperability with coherent FQPSK-B demodulators, some form of precoding must be applied to the data stream prior to, or in conjunction with, conversion to the ternary excitation alphabet. The differential encoder defined in paragraph 2.4.3.1.1 fulfills this need. However, to guarantee full interoperability with the other waveform options, the polarity relationship between frequency impulses and resulting frequency or phase change must be controlled. Thus, SOQPSK modulators proposed for this application shall guarantee that an impulse of value of (+1) will result in an advancement of the transmitted phase relative to that of the nominal carrier frequency (i.e., the instantaneous frequency is above the nominal carrier).

For purposes of this standard, only one specific variant of SOQPSK and SOQPSK-TG is acceptable. This variant is defined by the parameter values given in Table 2-4.

TABLE 2-4. SOQPSK-TG PARAMETERS				
SOQPSK TYPE	ρ	B	T_1	T_2
SOQPSK-TG	0.70	1.25	1.5	0.50

2.4.3.2.1 Differential Encoding of SOQPSK-TG. As discussed above, interoperability with FQPSK-B equipment requires a particular pre-coding protocol or a functional equivalent thereof. A representative model is shown in Figure 2-3.

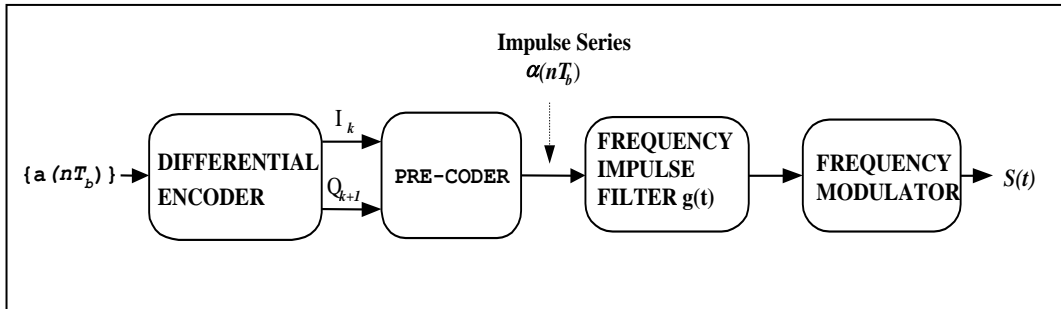

Figure 2-3. SOQPSK transmitter.

The differential encoder block will be implemented in accordance with the definition of paragraph 2.4.3.1.1. Given the symbol sequences I_k and Q_k , and the proviso that a normalized impulse sign of +1 will increase frequency, the pre-coder will provide interoperability with the FQPSK signals defined herein if code symbols are mapped to frequency impulses in accordance with Table 2-5 (below) where $\Delta\Phi$ is the phase change.

TABLE 2-5. SOQPSK PRE-CODING TABLE FOR IRIG-106 COMPATIBILITY									
MAP α_k FROM I_k					MAP α_{k+1} FROM Q_{k+1}				
I_k	Q_{k-1}	I_{k-2}	$\Delta\Phi$	α_k	Q_{k+1}	I_k	Q_{k-1}	$\Delta\Phi$	α_{k+1}
-1	X*	-1	0	0	-1	X*	-1	0	0
+1	X*	+1	0	0	+1	X*	+1	0	0
-1	-1	+1	$-\pi/2$	-1	-1	-1	+1	$+\pi/2$	+1
-1	+1	+1	$+\pi/2$	+1	-1	+1	+1	$-\pi/2$	-1
+1	-1	-1	$+\pi/2$	+1	+1	-1	-1	$-\pi/2$	-1
+1	+1	-1	$-\pi/2$	-1	+1	+1	-1	$+\pi/2$	+1

* Note: Does not matter if "X" is a +1 or a -1

2.4.3.3 Characteristics of Advanced Range Telemetry (ARTM) CPM. ARTM CPM is a quaternary signaling scheme in which the instantaneous frequency of the modulated signal is a function of the source data stream. The frequency pulses are shaped for spectral containment purposes. The modulation index alternates at the symbol rate between two values to improve the likelihood that the transmitted data is faithfully recovered. Although the following description is in terms of carrier frequency, other representations and generation methods exist that are equivalent. A block diagram of a conceptual ARTM CPM modulator is illustrated in Figure 2-4. Source bits are presented to the modulator and are mapped into impulses that are applied to a filter with an impulse response $g(t)$. The resulting waveform $f(t)$ is proportional to the instantaneous frequency of the desired modulator output. This signal can be used to frequency modulate a carrier to produce an RF signal representation.

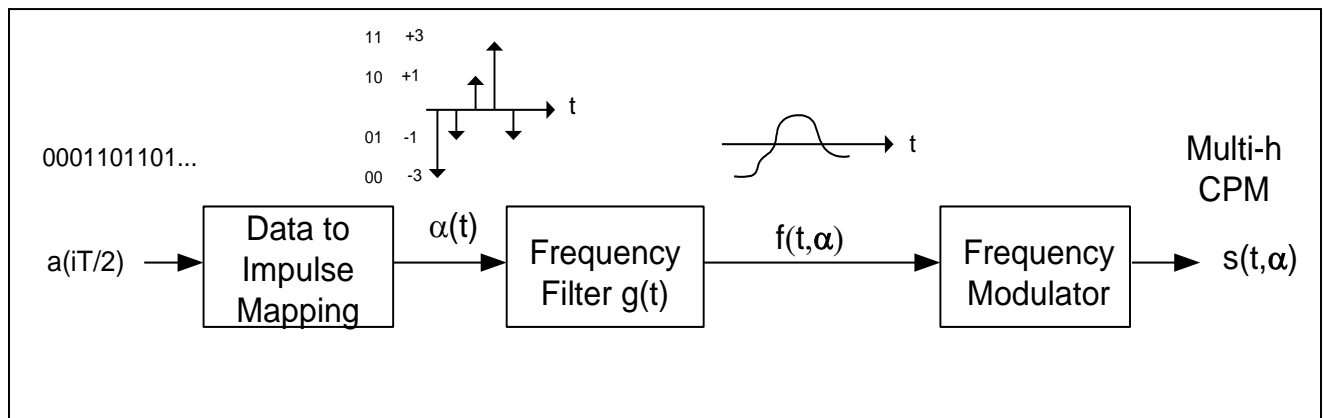

Figure 2-4. Conceptual CPM modulator.

Variables and function definitions in Figure 2-4 above are as follows:

- $a(iT/2)$ = i th bit of binary source data, either a 0 or 1
- The frequency pulse shape for ARTM CPM is a three symbol long raised cosine pulse defined by $g(t) = \frac{1}{6T} \left[1 - \cos\left(\frac{2\pi t}{3T}\right) \right]$ for $0 \leq t \leq 3T$ (2-11)
- T = Symbol period equal to $2/(\text{bit rate in bits/second})$
- $\alpha(iT)$ = i th impulse with area equal to either a +3,+1,-1 or -3 determined by Table 2-6 below. Note that an impulse is generated for each dibit pair (at the symbol rate).
- $f(t,\alpha)$ = frequency filter output equal to $\pi h_i \sum_{i=-\infty}^{+\infty} \alpha(iT)g(t - iT)$ (2-12)
- h = modulation index; h alternates between h_1 and h_2 where $h_1 = 4/16$, $h_2 = 5/16$

TABLE 2-6. DIBIT TO IMPULSE AREA MAPPING	
INPUT DIBIT [a(i) a(i+1)]	IMPULSE AREA
1 1	+3
1 0	+1
0 1	-1
0 0	-3

For more information on the ARTM CPM waveform, please refer to Appendix A of this document and to the publication at reference [6].

2.4.3.4 **Data Randomization.** The data input to the transmitter shall be randomized using either an encryptor that provides randomization or an Inter-range Instrumentation Group (IRIG) 15-bit randomizer as described in Chapter 6 and Appendix D. The purpose of the randomizer is to prevent degenerative data patterns from degrading data quality.

2.4.3.5 **Bit Rate.** The bit rate range for FQPSK-B, FQPSK-JR, and SOQPSK-TG shall be between 1 Mb/s and 20 Mb/s. The bit rate range for ARTM CPM shall be between 5 Mb/s and 20 Mb/s.

2.4.3.6 **Transmitter Phase Noise.** The sum of all discrete spurious spectral components (single sideband) shall be less than -36 dBc. The continuous single sideband phase noise power spectral density (PSD) shall be below the curve shown in Figure 2-5 below. The maximum frequency for the curve in Figure 2-5 is one-fourth of the bit rate. For bit rates greater than 4 Mb/s, the phase noise PSD shall be less than -100 dBc/Hz between 1 MHz and one-fourth of the bit rate.

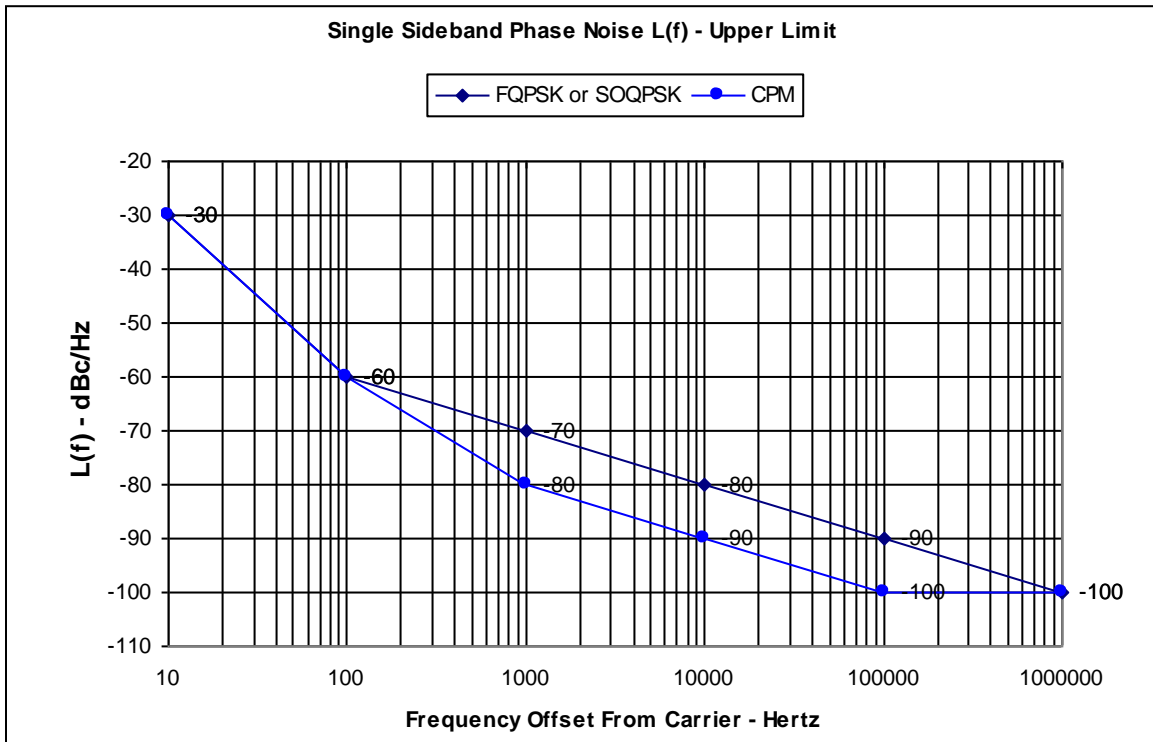

Figure 2-5. Continuous single sideband phase noise power spectral density.

2.4.3.7 Modulation Polarity. An increasing voltage at the input of a frequency modulation (FM) transmitter shall cause an increase in output carrier frequency. An increase in voltage at the input of a phase modulation (PM) transmitter shall cause an advancement in the phase of the output carrier. An increase in voltage at the input of an amplitude modulation (AM) transmitter shall cause an increase in the output voltage of the output carrier.

2.4.4 Spurious Emission and Interference Limits. Spurious⁷ emissions from the transmitter case, through input and power leads, and at the transmitter radio frequency (RF) output and antenna-radiated spurious emissions are to be within required limits shown in MIL-STD-461, *Electromagnetic Emission and Susceptibility Requirements for the Control of Electromagnetic Interference*. Other applicable standards and specifications may be used in place of MIL-STD-461 if necessary.

2.4.4.1 Transmitter-Antenna System Emissions. Emissions from the antenna are of primary importance. For example, a tuned antenna may or may not attenuate spurious frequency products produced by the transmitter, and an antenna or multi-transmitter system may generate spurious outputs when a pure signal is fed to its input. The transmitting pattern of such spurious frequencies is generally different from the pattern at the desired frequency. Spurious outputs in the transmitter output line shall be limited to -25 dBm. Antenna-radiated spurious outputs shall be no greater than 320 μ V/meter at 30 meters in any direction.

⁷ Any unwanted signal or emission is spurious whether or not it is related to the transmitter frequency (harmonic).

WARNING: Spurious levels of -25 dBm may severely degrade performance of sensitive receivers whose antennas are located in close proximity to the telemetry transmitting antenna. Therefore, lower spurious levels may be required in certain frequency ranges, such as near GPS frequencies.

2.4.4.2 Conducted and Radiated Interference. Interference (and the RF output itself) radiated from the transmitter or fed back into the transmitter power, signal, or control leads could interfere with the normal operation of the transmitter or the antenna system to which the transmitter is connected. All signals conducted by the transmitter's leads (other than the RF output cable) in the range of 150 kHz to 50 MHz, and all radiated fields in the range of 150 kHz to 10 GHz (or other frequency ranges as specified) must be within the limits of the applicable standards or specifications.

2.4.5 Operational Flexibility. Each transmitter shall be capable of operating at all frequencies within its allocated band without design modification.⁸

2.4.6 Modulated Transmitter Bandwidth.⁹ Telemetry applications covered by this standard shall use 99-percent power bandwidth to define occupied bandwidth and -25 dBm bandwidth as the primary measure of spectral efficiency. The -25 dBm bandwidth is the minimum bandwidth that contains all spectral components that are -25 dBm or larger. A power level of -25 dBm is exactly equivalent to an attenuation of the transmitter power by $55 + 10 \times \log(P)$ dB where P is the transmitter power expressed in watts. The spectra are assumed symmetrical about the transmitter's center frequency unless specified otherwise. All spectral components larger than $-(55 + 10 \times \log(P))$ dBc at the transmitter output must be within the spectral mask calculated using the following equation:

$$M(f) = K + 90 \log R - 100 \log |f - f_c|; |f - f_c| \geq \frac{R}{m} \quad (2-13)$$

where

- $M(f)$ = power relative to P (i.e., units of dBc) at frequency f (MHz)
- K = -20 for analog signals
- = -28 for binary signals
- = -61 for FQPSK-B, FQPSK-JR, SOQPSK-TG
- = -73 for ARTM CPM
- f_c = transmitter center frequency (MHz)
- R = bit rate (Mb/s) for digital signals or
- $(\Delta f + f_{\max})$ (MHz) for analog FM signals
- m = number of states in modulating signal;
- m = 2 for binary signals
- m = 4 for quaternary signals and analog signals
- Δf = peak deviation
- f_{\max} = maximum modulation frequency

⁸ The intent is that fixed frequency transmitters can be used at different frequencies by changing crystals or other components. All applicable performance requirements will be met after component change.

⁹ These bandwidths are measured using a spectrum analyzer with the following settings: 30-kHz resolution bandwidth, 300-Hz video bandwidth, and no max hold detector or averaging.

Note that the mask in this standard is different than the masks contained in earlier versions of the Telemetry Standards. Equation (2-13) does not apply to spectral components separated from the center frequency by less than R/m . The -25 dBm bandwidth is not required to be narrower than 1 MHz. Binary signals include all modulation signals with two states while quaternary signals include all modulation signals with four states (quadrature phase shift keying and FQPSK-B are two examples of four-state signals). Appendix A, paragraph 6.0, contains additional discussion and examples of this spectral mask.

2.4.7 Valid Center Frequencies Near Telemetry Band Edges. The telemetry bands, as specified, start and stop at discrete frequencies. Telemetry transmitters transmitting PCM/FM or SOQPSK-TG/FQPSK-B/FQPSK-JR or ARTM CPM, even with optimal filtering, do not have discrete start and stop frequencies. In order to determine a valid carrier frequency, the transmitter power, modulation scheme, and data rate must be known. The distance, in frequency, from the point in which the spectral masks, as described in paragraph 2.4.6, intersect the absolute value of -25 dBm equals the amount in which the transmitter carrier frequency must be from the band edge frequency. Paragraph 12.0 of Appendix A contains additional discussion and examples of center frequency determination when operating near telemetry band edges.

2.5 Telemetry Receiver Systems

As a minimum, receiver systems shall have the following characteristics.

2.5.1 Spurious Emissions. The RF energy radiated from the receiver itself or fed back into the power supply, and/or the RF input, output, and control leads in the range from 150 kHz to 10 GHz shall be within the limits specified in MIL-STD 461. The receiver shall be tested in accordance with MIL-STD 461 or RCC Document 118, volume II, Test Methods for Telemetry RF Subsystems. Other applicable standards and specifications may be used in place of MIL-STD-461, if necessary.

2.5.2 Frequency Tolerance. The accuracy of all local oscillators within the receiver shall be such that the conversion accuracy at each stage and overall is within ± 0.001 percent of the indicated tuned frequency under all operating conditions for which the receiver is specified.

2.5.3 Receiver Phase Noise. The sum of all discrete spurious spectral components (single sideband) shall be less than -39 dBc. The continuous single sideband phase noise power spectral density (PSD) shall be 3 dB below the curve shown in Figure 2-5. The maximum frequency for the curve in Figure 2-5 is one-fourth of the bit rate. For bit rates greater than 4 Mb/s, the phase noise PSD shall be less than -103 dBc/Hz between 1 MHz and one-fourth of the bit rate.

2.5.4 Spurious Responses. Rejection of any frequency other than the one to which the receiver is tuned shall be a minimum of 60 dB referenced to the desired signal over the range 150 kHz to 10 GHz.

2.5.5 Operational Flexibility. All ground-based receivers shall be capable of operating over the entire band for which they are designed. External down-converters may be either intended for the entire band or a small portion but capable of retuning anywhere in the band without modification.

2.5.6 Intermediate Frequency (IF) Bandwidths. The standard receiver IF bandwidths are shown in Table 2-7. These bandwidths are separate from and should not be confused with post-detection low-pass filtering that receivers provide.¹⁰ The ratio of the receiver's -60 dB bandwidth to the -3 dB bandwidth shall be less than 3 for new receiver designs.

TABLE 2-7. STANDARD RECEIVER INTERMEDIATE FREQUENCY (IF) BANDWIDTHS		
300 kHz	1.5 MHz	6 MHz
500 kHz	2.4 MHz	10 MHz
750 kHz	3.3 MHz	15 MHz
1000 kHz	4.0 MHz	20 MHz

NOTE

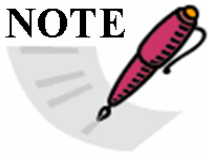

1. For data receivers, the IF bandwidth should typically be selected so that 90 to 99 percent of the transmitted spectrum is within the receiver 3 dB bandwidth. In most cases, the optimum IF bandwidth will be narrower than the 99 percent power bandwidth.
2. Bandwidths are expressed at the points where response is 3 dB below the response at the design center frequency, assuming that passband ripple is minimal, which may not be the case. The 3-dB bandwidth is chosen because it closely matches the noise bandwidth of a "brick-wall" filter of the same bandwidth. The "optimum" bandwidth for a specific application may be other than that stated here. Ideal IF filter response is symmetrical about its center frequency; in practice, this may not be the case.
3. Not all bandwidths are available on all receivers or at all test ranges. Additional receiver bandwidths may be available at some test ranges especially if the range has receivers with digital IF filtering

¹⁰ In most instances, the output low-pass filter should *not* be used to "clean up" the receiver output prior to use with demultiplexing equipment.

2.5.7 C-band Downconversion. For telemetry receive systems employing C-band downconversion, the following mapping of C-band RF to C-band IF frequencies is recommended for the Lower C and Middle C Bands. This downconversion scheme utilizes a high side Local Oscillator frequency of 5550 MHz to minimize the potential of mixing products interfering with received telemetry signals. Additionally, using a standardized approach fosters interoperability between manufacturers of telemetry antenna systems employing downconversion and manufacturers of telemetry receivers with C-IF tuners.

No recommendation will be made at this point for the downconversion of the Upper C-band (5925-6700 MHz).

Examples:

$$\text{C-IF Frequency} = (5550 \text{ MHz} - \text{C-RF Frequency})$$

$$1150 \text{ MHz} = (5550 \text{ MHz} - 4400 \text{ MHz})$$

$$610 \text{ MHz} = (5550 \text{ MHz} - 4940 \text{ MHz})$$

$$459 \text{ MHz} = (5550 \text{ MHz} - 5091 \text{ MHz})$$

$$400 \text{ MHz} = (5550 \text{ MHz} - 5150 \text{ MHz})$$

REFERENCES

- [1] Hogenauer, E., "An Economical Class of Digital Filters for Decimation and Interpolation, IEEE Transactions on Acoustics, Speech, and Signal Processing," Vol. ASSP-29, No. 2, April 1981.
- [2] Hill T., "An Enhanced, Constant Envelope, Interoperable Shaped Offset QPSK(SOQPSK) Waveform for Improved Spectral Efficiency," Proceedings of the International Telemetry Conference, San Diego, California, October 2000.
- [3] Younes B., Brase J., Patel C., Wesdock J., "An Assessment of Shaped Offset QPSK for Use in NASA Space Network and Ground Network Systems," Meetings of Consultative Committee for Space Data Systems, Toulouse, France, October, 2000.
- [4] Geoghegan, M., "Implementation and Performance Results for Trellis Detection of SOQPSK," Proceedings of the International Telemetry Conference, Las Vegas, Nevada, October 2001.
- [5] Simon, M., "Bandwidth-Efficient Digital Modulation with Application to Deep Space Communications," Monograph number 3, DESCANSO Monograph Series, JPL Publication 00-17, Jet Propulsion Laboratory, California Institute of Technology, 2001. This publication is available free via the Internet at [DESCANSO: Deep Space Communications and Navigation Systems](#)
- [6] Geoghegan, M. "Description and Performance Results for the multi-h CPM Tier II Waveform," Proceedings of the International Telemetry Conference, San Diego, CA, October 2000.

**** END CHAPTER 2 ****