

CHAPTER 6

DIGITAL CASSETTE HELICAL SCAN RECORDER/REPRODUCER, MULTIPLEXER/DEMULPLEXER, TAPE CASSETTE, AND RECORDER CONTROL AND COMMAND MNEMONICS STANDARDS

TABLE OF CONTENTS

LIST OF FIGURES		i
LIST OF TABLES		ii
ACRONYMS		iii
<u>Paragraph</u>	<u>Subject</u>	<u>Page</u>
6.1	Introduction.....	6-1
6.2	Definitions	6-2
6.3	19-mm Digital Cassette Helical Scan Recording Standards.....	6-8
6.4	Multiplex/Demultiplex (MUX/DEMUX) Standard for Multiple Data Channel Recording on 19-MM Digital Cassette Helical Scan Recorder/Reproducer Systems.....	6-10
6.5	Submultiplex/Demultiplex Standards for Multiple Data Channels on a Primary Digital Multiplex/Demultiplex Channel	6-14
6.6	1/2 Inch Digital Cassette (S-VHS) Helical Scan Recording Standards.....	6-18
6.7	Multiplex/Demultiplex (MUX/DEMUX) Standards for Multiple Data Channel Recording on 1/2 Inch Digital Cassette (S-VHS) Helical Scan Recorder/Reproducer Systems.....	6-35
6.8	Recorder Command and Control Mnemonics (CCM).....	6-41

LIST OF FIGURES

Figure 6-1.	Head and head segment mechanical parameters.....	6-8
Figure 6-2.	Location and dimensions of recorded tracks.	6-9
Figure 6-3.	ADARIO block format.	6-11
Figure 6-4.	ADARIO data format.....	6-13
Figure 6-5.	Submux data format.....	6-17
Figure 6-6.	Helical track dimensions, B format.	6-19
Figure 6-7.	Helical track dimensions, E format.....	6-20
Figure 6-8.	Recorded tracks on tape, B format.....	6-23
Figure 6-9.	Tape cartridge layout.	6-24
Figure 6-10.	Helical track format.	6-27
Figure 6-11.	Typical VLDS data path electronics block diagram.	6-29
Figure 6-12.	Interleave buffer architectures.	6-30
Figure 6-13.	The steps of the build process.....	6-36

LIST OF TABLES

Table 6-1.	Record Location and Dimensions	6-9
Table 6-2.	Tape Length and Nominal Play Record/ Reproduce Time at 240 Megabits/Second User Data Rate	6-10
Table 6-3.	ADARIO Format (FMT) Defined Field Restrictions	6-12
Table 6-4.	Physical Parameters	6-21
Table 6-5.	Track and Data Sync: Word 0-Word 4	6-27
Table 6-6.	Track and Data Sync: Word 5.....	6-28
Table 6-7.	ECC - Interleave Buffer Addressing (32 mbps)	6-31
Table 6-8.	ECC - Interleave Buffer Addressing (64 mbps)	6-31
Table 6-9.	Tape - Interleave Buffer Addressing (32 mbps)	6-32
Table 6-10.	Tape - Interleave Buffer Addressing (64 mbps)	6-33
Table 6-11.	Miscellaneous Bit Definitions	6-34
Table 6-12.	Scanlist Build Steps	6-37
Table 6-13.	Sample Armor Frame.....	6-38
Table 6-14.	Time Code Word Format.....	6-39
Table 6-15.	Command Summary	6-43
Table 6-16.	Command Error Codes	6-44
Table 6-17.	Use of Status Bits.....	6-52
Table 6-18.	Recorder States	6-59
Table 6-19.	Command Validity Matrix.....	6-64
Table 6-20.	Required Commands.....	6-65

ACRONYMS

ADARIO	Analog/Digital/ Adaptable/Recorder Input/Output
AFVP	Format Verification Program
ANSI	American National Standards Institute
ARMOR	asynchronous real-time multiplexer and output reconstructor
BCD	Binary-coded decimal
BER	Bit error rate
BOD	beginning of data
BOF	beginning of file
BOM	beginning of media
BRC	The block rate clock
CCM	Command and Control Mnemonics
CWDS	Code word digital sum OR word digital sum
DSV	Digital sum variation
ECC	Error correcting code
ECC	error correction coding
ECL	Emitter-Coupled Logic
EOD	end of data
EOF	end of file
EOM	end of media
ftpmm	flux transitions per millimeter
GF	Galois field
LBOT	logical beginning of tape
LEOT	logical end of tape
Mbps	megabits per second
MML	Magnetic Media Laboratory
MSB	most significant bit
MUX/DEMUX	Multiplex/Demultiplex
PAR	parallel
PBN	Principal block number
PBOT	physical beginning of tape
PCM	Pulse-code modulation
PEOT	physical end of tape
RS	Reed-Solomon
SI	Systeme International d' Unites
submux	submultiplex
TTL	Transistor-Transistor Logic
UBE	upper band edge
VLDS	very large data store

This page intentionally left blank.

CHAPTER 6

DIGITAL CASSETTE HELICAL SCAN RECORDER/REPRODUCER, MULTIPLEXER/DEMULPLEXER, TAPE CASSETTE, AND RECORDER CONTROL AND COMMAND MNEMONICS STANDARDS

6.1 Introduction

These standards define terminology for digital cassette helical scan (19-mm and ½ inch) recording systems, along with the associated multiplexer/demultiplexer systems, digital tape cassettes, and recorder control and command mnemonics. Standards consistent with compatibility in interchange transactions are delineated. While the standards may serve as a guide in the procurement of magnetic tape recording equipment, they are not intended to be employed as substitutes for purchase specifications. The American National Standards Institute (ANSI) and the International Standards Organization have prepared other related standards (see paragraph 1.0, appendix D).

United States (U.S.) engineering units are the original dimensions in these standards. Conversions for U.S. engineering units (similar to British Imperial Units) to Systeme International d' Unites (SI) units have been done according to ANSI Z210.1-1976 (and International Standards Organization 370) Method A, except as noted.

Standard test methods for digital cassette helical scan recorder/reproducers and multiplexer/demultiplexer systems are contained in RCC Document 118, Volume III, Test Methods for Recorder/Reproducer Systems and Magnetic Tape.

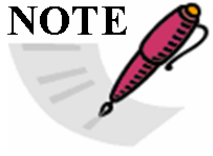
 <p>NOTE</p>	<p>The standards for longitudinal fixed-head recorder and reproducer systems have been removed from this chapter and are now contained in Appendix D, paragraphs 12.0 through 21.2. Standards for longitudinal instrumentation magnetic tape previously contained in Chapter 7 can now be found in Appendix D, paragraphs 22.0 through 27.11.</p>
--	---

6.2 Definitions

5/6 modulation code: A method of encoding whereby a 5-bit data group is converted to a 6-bit code frame in accordance with a conversion table. Such coding is performed to control the frequency content of the data stream.

Basic dimension: A dimension specified on a drawing as basic is a theoretical value used to describe the exact size, shape, or location of a feature. It is used as the basis from which permissible variations are established by tolerances on other dimensions.

Bias signal, high frequency: A high-frequency sinusoidal signal linearly added to the analog data signal in direct recording to linearize the magnetic recording characteristic.

Bi-phase: A method of representing "one" or "zero" levels in PCM systems where a level change is forced to occur in every bit period. In bi-phase recording, the bi-phase level (split-phase) method is employed.

Bit error: In PCM systems, a bit error has occurred when the expected bit value is not present; for example, a zero is present when a one is expected, or a one is present when a zero is expected.

Bit error rate (BER): Number of bits in error in a predetermined number of bits transmitted or recorded, for example, 1 in 10⁶ or a BER of 10⁻⁶.

Bit packing density, linear: Number of bits recorded per inch or per millimeter of tape length. For serial PCM recording, the number of bits per unit length of a single track.

Bit slip: The increase or decrease in detected bit rate by one or more bits with respect to the actual bit rate.

Code frame: An ordered and contiguous set of bits (symbol) that results as a unit from the process of modulation coding.

Code word digital sum (CWDS): Denotes the digital sum variation of one modulation code frame (symbol).

Crossplay: Reproducing a previously recorded tape on a recorder and reproducer system other than that used to record the tape.

Crosstalk: Undesired signal energy appearing in a reproducer channel as a result of coupling from other channels.

Data azimuth (dynamic): The departure from the head segment gap azimuth angles (static) because of the dynamic interface between the heads and the moving tape.

Data scatter: The distance between two parallel lines (as defined under gap scatter) in the plane of the tape, which contains all data transitions recorded simultaneously with the same head at the same instant of time.

Data spacing: For interlaced head systems, the distance on tape between simultaneous events recorded on odd and even heads.

Digital sum variation (DSV): Indicates the integral value that is counted from the beginning of the modulation coded waveform, taking a high level as 1 and a low level as -1.

Direct Recording (ac Bias Recording): A magnetic recording technique employing a high-frequency bias signal that is linearly added to the data signal. The composite signal is then used as the driving signal to the record-head segment. The bias signal, whose frequency is well above the highest frequency that can be reproduced by the system, transforms the recording of the data signal so that it is a more nearly linear process.

Double-density recording: Direct, FM, or PCM recording on magnetic tape at bandwidths equal to those used in wide-band instrumentation recording, but at one-half the wide-band tape speeds specified in IRIG standard 106-80 and earlier telemetry standards. Special record and reproduce heads and high output tapes (see Chapter 7) are required for double-density recording.

Dropout: An instantaneous decrease in reproduced signal amplitude of a specified amplitude and duration.

ECC code word: The group of symbols resulting from ECC encoding including the data symbols and the check symbols appended.

Edge margin: The distance between the outside edge of the highest number track and the tape edge (see Appendix D, D-7Aa).

Edge margin minimum: The minimum value of edge margin.

Error correcting code (ECC): A mathematical procedure yielding bits used for the detection and correction of errors.

FM recording: Recording on magnetic tape using frequency-modulated record electronics to obtain response from dc to an upper specified frequency. The FM systems forfeit upper bandwidth response of direct record systems to obtain low frequency and dc response not available with direct recording.

Flux transition: A 180-degree change in the flux pattern of a magnetic medium brought about by a reversal of poles within the medium.

Flux transition density: Number of flux transitions per inch or per millimeter of track length.

Flutter: Undesired changes in the frequency of signals during the reproduction of a magnetic tape produced by speed variations of the magnetic tape during recording or reproducing.

Gap azimuth: The angular deviation, in degrees of arc, of the recorded flux transitions on a track from the line normal to the track centerline.

Gap length (physical): The dimension between leading and trailing edges of a record or reproduce head-segment gap measured along a line perpendicular to the leading and trailing edges of the gap.

Gap scatter (record head): The distance between two parallel lines is defined in the following subparagraphs.

- a. The two lines pass through the geometric centers of the trailing edges of the two outermost head segment gaps within a record head. The geometric centers of the other head segment gap trailing edges lie between the two parallel lines.
- b. The two parallel lines lie in the plane of the tape and are perpendicular to the head reference plane (see Appendix D, Figure D-7b)

Gap scatter (reproduce head): Defined the same as for record-head gap scatter except that the reference points for reproduce heads are the geometric centers of the center lines of the head segment gaps (Appendix D, Figure D-7c).

Guard band: The unrecorded space between two adjacent recorded tracks on the magnetic tape.

Head (record or reproduce): A group of individual head segments mounted in a stack.

Head designation: For interlaced heads, the first head of a record or reproduce pair over which the tape passes in the forward direction containing odd-numbered head segments and referred to as the odd head. The second head containing even-numbered head segments is the even head. For non-interlaced heads (in-line heads), both odd- and even-numbered head segments are contained within a single head.

Heads, in-line: A single record head and a single reproduce head are employed. Odd and even record-head segment gaps are in-line in the record head. Odd and even reproduce-head segment gaps are in-line in the reproduce head.

Head reference plane: The plane, which may be imaginary, is parallel to the reference edge of the tape and perpendicular to the plane of the tape. For purposes of this definition, the tape shall be considered as perfect (see Appendix D, Figure D-7b, and Figure D-7c).

Head segment, record or reproduce: A single transducer that records or reproduces one track (see Appendix D, Figure D-7b).

Head segment gap azimuth (record or reproduce heads): The angle formed in the plane of the tape between a line perpendicular to the head reference plane and a line parallel to the trailing

edge of the record-head segment gap or parallel to the centerline of the reproduce-head segment gap.

Head segment gap azimuth scatter: The angular deviations of the head segment gap azimuth angles within a head.

Head segment numbering: Numbering of a head segment corresponds to the track number on the magnetic tape on which that head segment normally operates. For interlaced heads, the odd head of a pair contains all odd-numbered segments, while the even head will contain all even-numbered segments (see Appendix D, Figure D-7c). In-line heads will contain odd and even segments in the same head stack.

Head spacing: For interlaced head systems, the distance between odd and even heads.

Head tilt: The angle between the plane tangent to the front surface of the head at the center line of the head segment gaps and a line perpendicular to the head reference plane (see Appendix D, Figure D-7b).

Heads, interlaced: Two record heads and two reproduce heads are employed. Head segments for alternate tracks are in alternate heads.

Helical track: A diagonally positioned area on the tape along which a series of magnetic transitions is recorded.

High-density digital recording: Recording of digital data on a magnetic medium resulting in a flux transition density in excess of 590 transitions per millimeter (15 000 transitions per inch) per track.

Individual track data azimuth difference: Angular deviation of the data azimuth of an individual odd or even recorded track from the data azimuth of other odd or even tracks. The difficulty in making direct optical angular measurements requires this error to be expressed as a loss of signal amplitude experienced when the tape is reproduced with an ideal reproducing head, whose gap is aligned to coincide with the data azimuth of all tracks in one head as compared to the azimuth which produces maximum signal for an individual track (see Appendix D, and Figure D-7b).

Interleaving: The systematic reordering of data so that originally adjacent ECC code word symbols are separated, thus reducing the effect of burst errors on the error correcting capability.

Non-return-to-zero level: A binary method of representation for PCM signals where one is represented by one level and zero is defined as the other level in a bi-level system.

Physical recording density: The number of recorded flux transitions per unit length of track, for example, flux transitions per millimeter (ftpmm).

Principal block: Denotes a group of helical tracks recorded on the tape in one complete rotation of the scanner.

Principal block number (PBN): A unique number assigned to and recorded in each principal block.

Record level set frequency: Frequency of a sinusoidal signal used to establish the standard record level in direct-record systems. Normally, 10 percent of the upper band edge (UBE) frequency.

Reference tape edge: When viewing a magnetic tape from the oxide surface side with the earlier recorded portion to the observer's right, the reference edge is the top edge of the tape (see Appendix D, Figure D-7a).

Reference track location: Location of the centerline of track number 1 from the reference edge of tape.

Scanner: The rotating assembly housing the helical heads around which the tape is applied thereby accomplishing the recording of helical tracks on the tape.

Standard record level: For a magnetic tape recorder meeting IRIG standards and operating in the direct record mode, the input signal level produces 1 percent third harmonic distortion of the record level set frequency.

Tape skew: Motion of a magnetic tape past a head such that a line perpendicular to the tape reference edge has an angular displacement (static or dynamic) from the head gap centerlines.

Tape speed, absolute: The tape speed during recording and reproducing. The peripheral velocity of the capstan minus any tape slip, regardless of tape tension and environment.

Tape speed, effective: The tape speed modified by the effects on tape of operating conditions such as tension, tape materials, thickness, temperature, and humidity. The effective tape speed should be equal to the selected speed of the recorder, for example, 1524 mm/s (60 ips), 3048 mm/s (120 ips), regardless of operating conditions.

Tape speed errors: Errors are the departures of the effective speed from the selected tape speed.

Track angle: The angular deviation, in degrees of arc, of the centerline of the recorded helical track from the tape reference edge.

Track location: Location of the nth track centerline from the reference track centerline.

Track numbering: The reference track is designated as track number 1. Tracks are numbered consecutively from the reference track downward when viewing the oxide surface of the tape

with the earlier recorded portion of the tape to the observer's right (see Appendix D, and Figure D-7a).

Track spacing: Distance between adjacent track centerlines on a magnetic tape (see Appendix D, and Figure D-7a).

Track width: The physical width of the common interface of the record-head segment at the gaps. This definition does not include the effects of fringing fields, which will tend to increase the recorded track width by a small amount.

Volume label: A group of bits used to provide an identifying code for a tape cartridge

6.3 19-mm Digital Cassette Helical Scan Recording Standards

These standards are for single-channel high-bit rate helical scan digital recorders using 19 mm tape cassettes. Bit rates of less than 10 megabits per second to 256 megabits per second or greater may be recorded and reproduced by equipment conforming to these standards. Interchange parties must, however, determine the availability at a particular site of the equipment required to meet particular data recording requirements. Compatibility between the recording device and the expected playback equipment must also be considered. Figure 6-1 displays the head and head segment mechanical parameters for a single-channel high-bit rate helical scan digital recorder.

6.3.1 Track Format. The format recorded and reproduced by these systems shall be as specified in American National Standard For Information Systems 19 mm Type ID-1 Recorded Instrumentation Digital Tape Format, ANSI INCITS 175-1999.¹ Helical tracks employ azimuth recording wherein the head gap angle with respect to the recorded track center line is $90^\circ + 15^\circ$ for one scan and $90^\circ - 15^\circ$ for the adjacent scan. Figure 6-2 and Table 6-1 show details of the helical tracks and auxiliary longitudinal tracks for control, timing, and annotation in the ID-1 format.

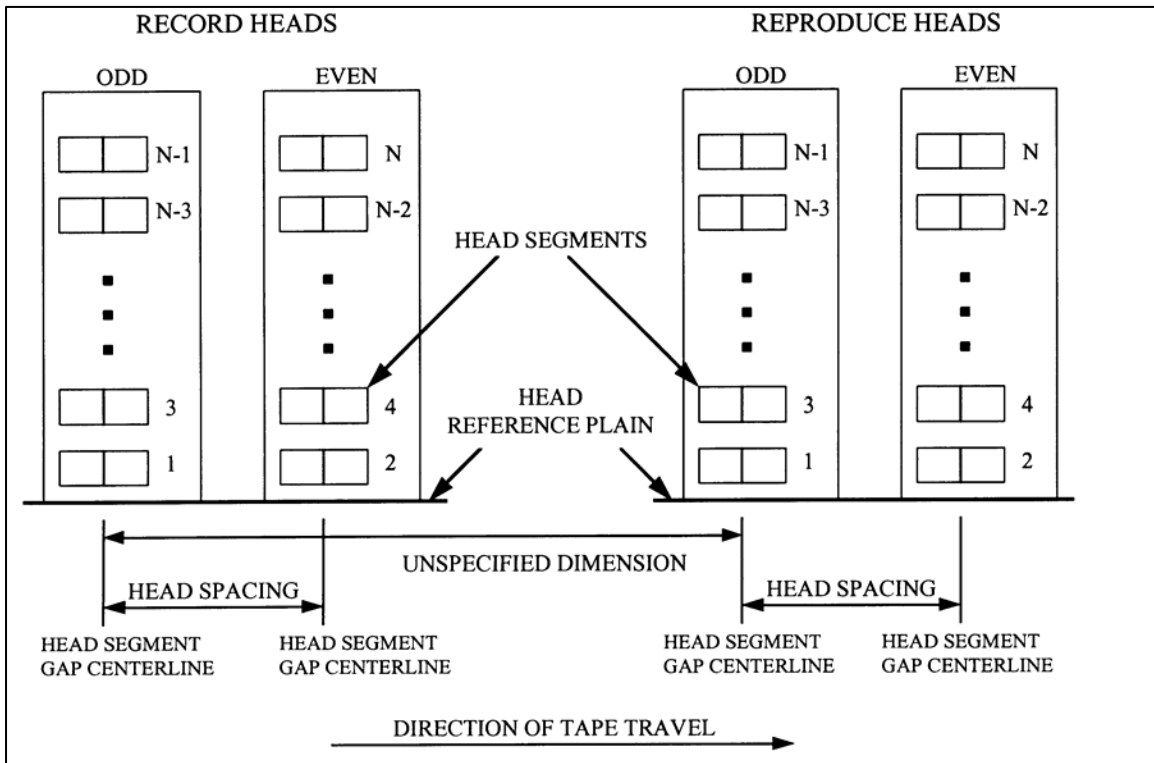

Figure 6-1. Head and head segment mechanical parameters.

¹ Formerly ANSI -1990. Available from American National Standards Institute (webstore.ansi.org).

TABLE 6-1. RECORD LOCATION AND DIMENSIONS		
Dimensions		Nominals
A	TIME-CODE TRACK LOWER EDGE	0.2 mm
B	TIME-CODE TRACK UPPER EDGE	0.7 mm
C	CONTROL TRACK LOWER EDGE	1.0 mm
D	CONTROL TRACK UPPER EDGE	1.5 mm
E	DATA-AREA LOWER EDGE	1.8 mm
F	DATA-AREA WIDTH	16 mm
G	ANNOTATION TRACK LOWER EDGE	18.1 mm
H	ANNOTATION TRACK UPPER EDGE	18.8 mm
I	HELICAL TRACK WIDTH	0.045 mm
J	TRACK PITCH, BASIC	0.045 mm
N	HELICAL TRACK TOTAL LENGTH	170 mm
P	ANNOTATION/TIME-CODE HEAD LOCATION	118.7 mm
R	SECTOR RECORDING TOLERANCE	±0.1 mm
T	CONTROL TRACK SYNC TOLERANCE	±0.1 mm
P	TRACK ANGLE, ARC-SINE (16/170)	5.4005°
W	TAPE WIDTH	19.01 mm

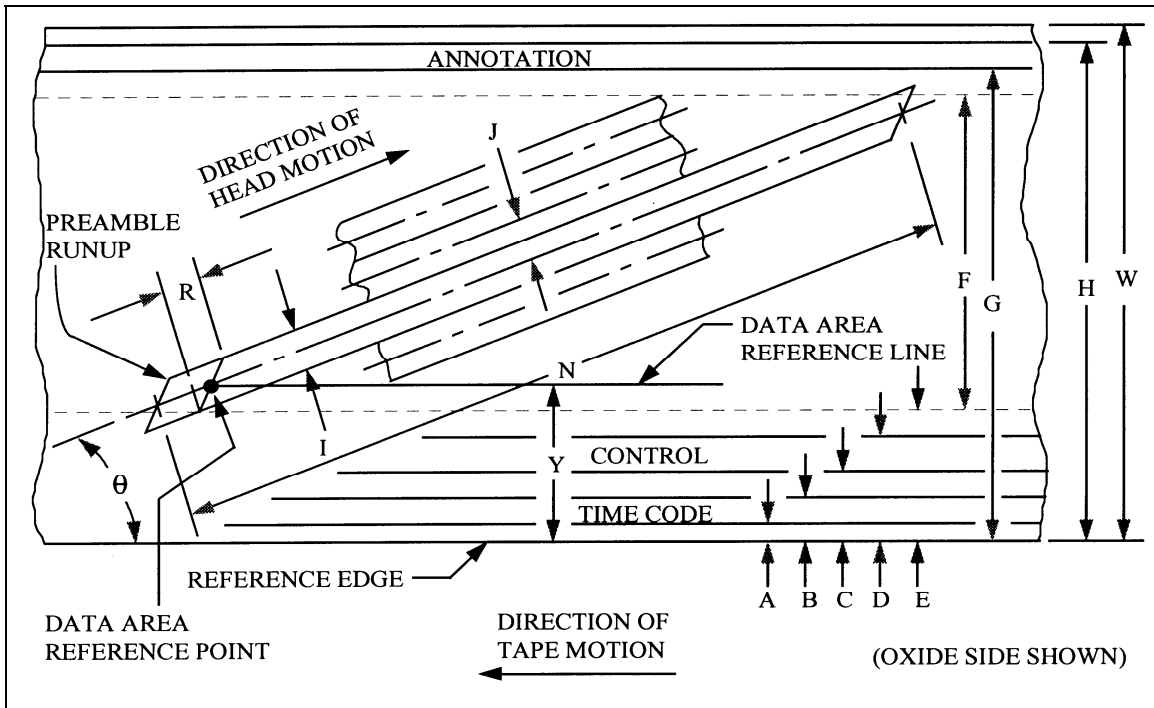

Figure 6-2. Location and dimensions of recorded tracks.

6.3.2 Magnetic Tape and Cassettes. The magnetic tape shall meet the requirements of Magnetic Media Laboratory (MML) Document 94-1, Specification for Rotary Instrumentation Magnetic Recording Tape, 19-millimeter (0.75 inch) Wide, 68 KA/M (850 Oersteds)². A tape base thickness of 16 μm is normally employed. The recorder/reproducers shall be capable of using 19 mm cassettes that conform to the physical dimensions of medium and large cassettes as defined in SMPTE 226M³ and as shown in Table 6-2. Table 6-2 shows tape capacities and indicates the amount of time available for recording, assuming a data input rate of 240 megabits per second.

6.3.3 Recorder/Reproducer Input and Output. Data input and clock are required. The data input shall be in an 8-bit parallel, byte serial format, and the clock signal will be at the required byte rate. Data output will also be in 8-bit parallel format.

TABLE 6-2. TAPE LENGTH AND NOMINAL PLAY RECORD/ REPRODUCE TIME AT 240 MEGABITS/SECOND USER DATA RATE			
Cassette	Tape Thickness (micrometers)	Tape Length (meters)	Play Time (minutes)
Medium	16	587	24
Large	16	1311	55
CASSETTE DIMENSIONS NOMINAL			
Cassette	Length	Width	Thickness
Medium	254 mm	150 mm	33 mm
Large	366 mm	206 mm	33 mm

6.4 Multiplex/Demultiplex (MUX/DEMUX) Standard for Multiple Data Channel Recording on 19-MM Digital Cassette Helical Scan Recorder/Reproducer Systems

For recording and reproducing multiple channels on 19-mm Digital Cassette Helical Scan Recorders, the ADARIO multiplex/demultiplex format is recommended. The ADARIO (Analog/Digital/ Adaptable/Recorder Input/Output) format was developed for the Department of

² MML Document 94-1 is available from the Naval Air Warfare Center Aircraft Division, Patuxent River, W Maryland 20670.

³ SMPTE 226M is available from the Society of Motion Picture and Television Engineers, 595 West Hartdale Avenue, White Plains, New York 10607.

Defense, Fort Meade, Maryland. The format is government-owned and may, therefore, be used in equipment provided for government activities. Some of the ADARIO features are:

- a. Requires less than 3 percent overhead to be added to user data.
- b. Accommodates multiple channel record/playback with each channel completely autonomous in sample rate and sample width.
- c. Stores all the necessary parameters for channel data reconstruction for real-time playback, time-scaled playback, or computer processing.
- d. Preserves phase coherence between data channels.
- e. Provides channel source and timing information.
- f. Accommodates 2^{24} (over 16 million) blocks of data, each block having 2048 24-bit words (see Figure 6-3).

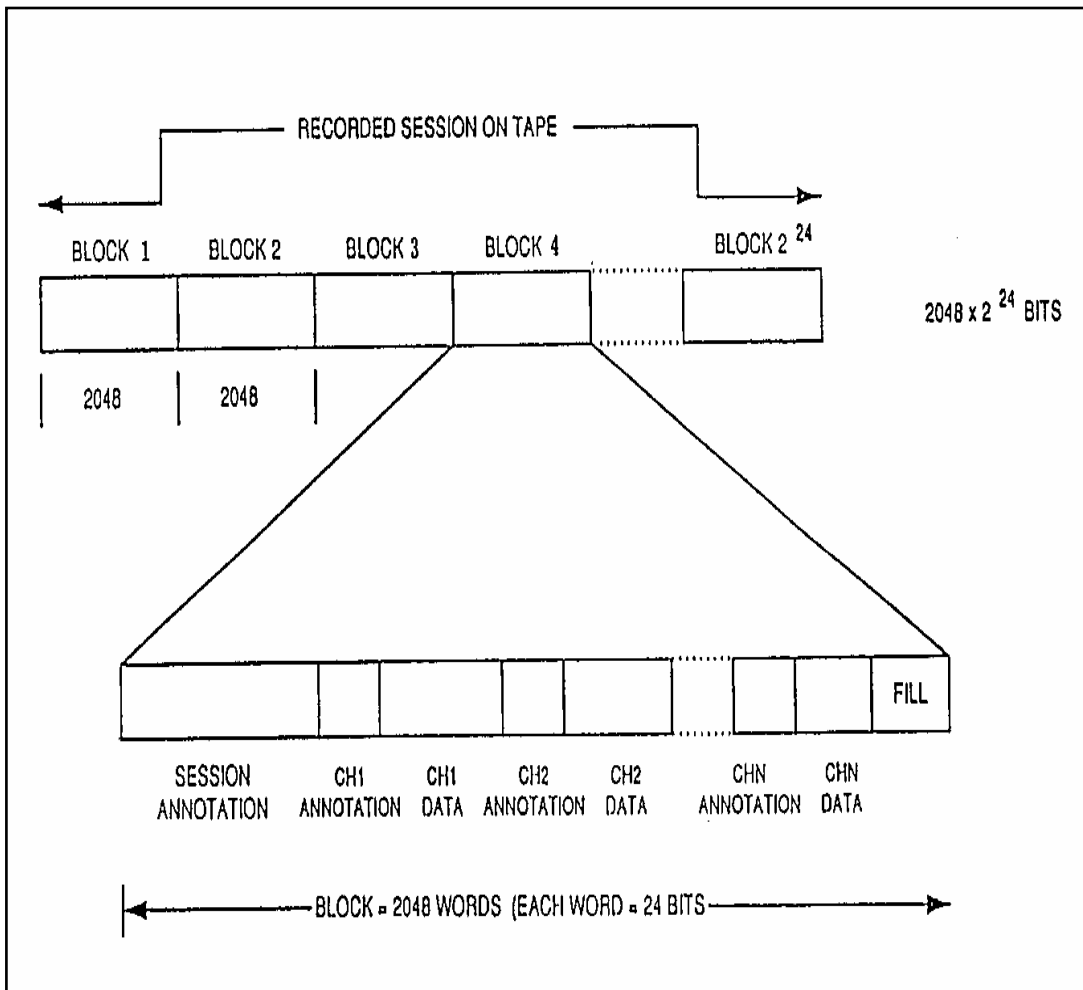

Figure 6-3. ADARIO block format.

The ADARIO format imposes minimum restrictions on the channel signals and aggregate data parameters. Specific implementations that use the ADARIO format may impose additional restrictions. ADARIO format, defined field restrictions are listed in [Table 6-3](#) below:

TABLE 6-3. ADARIO FORMAT (FMT) DEFINED FIELD RESTRICTIONS	
Field	Restrictions
Session length	Unlimited
Sequence numbered	Blk. 2^{24} (100 G byte max.)
Master clock	MC 2^{19} *250 Hz (131 MHz max.)
Block rate	BMD, MC/BMD (8 blk./sec min.) MC/2048 (64K blk./sec. max.)
Aggregate rate	MC *24 (3145 Mbps max.)
Channel quantity	Q, Ch#, 2^4 (16 channels max.)
Bits per sample	FMT, 1,2,3,4,5,6,7,8,10,12,14,16,18,20,22,24 bits per sample
Input clock rate	MC, Rate 2^{19} *250 Hz (131 MHz max.)
Input bit rate	2035 *24 block rate (3125 Mbps max.)
Analog bandwidth	MC/2.5 (52.4 MHz max.)
Analog attenuation	Atten, 2^5 (-15 dB, +16 dB)
Analog coupling	DCAC (dc or ac)
Time correlation	1/MC (7.6 ns max. resolution) TD/MC 2^{16} (65, 536*MC max. range)
Channel card types	CHT, 2^6 (64 max.)

Channel input digital data can be in any format, serial or parallel, in any coding, and at any levels, TTL, ECL, that can be accommodated by the channel type card used. Channel input analog signals can contain any form of modulation, at any nominal level, with any dynamic within the limitations (see Figure [6-4](#)).

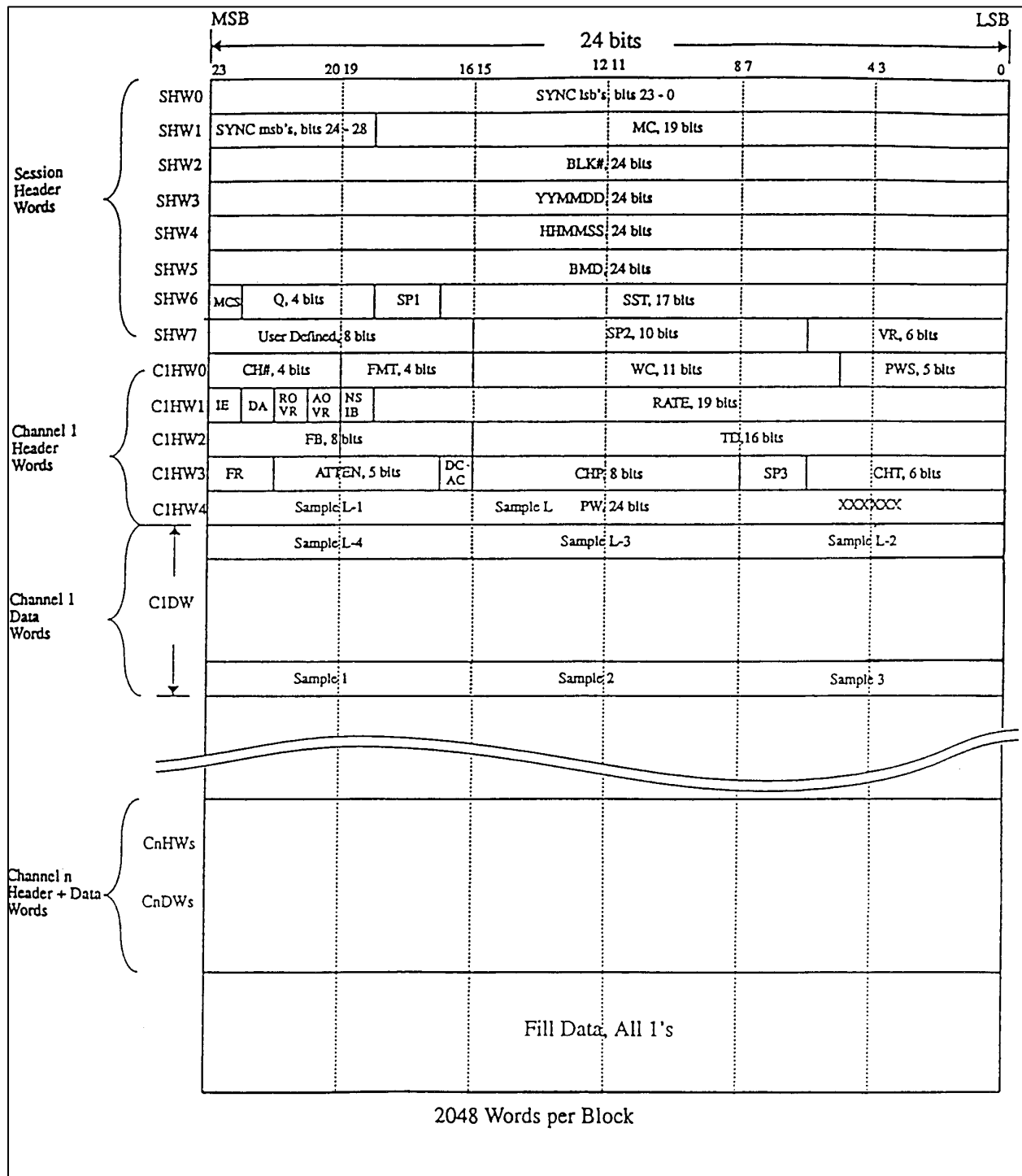

Figure 6-4. ADARIO data format.

6.5 Submultiplex/Demultiplex Standards for Multiple Data Channels on a Primary Digital Multiplex/Demultiplex Channel

For combining multiple low to medium rate telemetry channels on a single primary digital channel such as the ADARIO input channel, the submultiplex (submux) format is recommended. The format was developed for test range applications where high quantity of channels must be collected in conjunction with high data rate primary channels. The submux format provides a standard for extending the ADARIO primary channel or any other primary digital channel for conveying data from up to 31 subchannels in digital aggregate data form. Each channel is totally autonomous and can be enabled or disabled at any time. Some of the features of the submux format are:

- a. Accommodates analog, digital clocked and asynchronous, time and annotation text, and other application specific telemetry channels.
- b. Requires less than 0.3 percent of overhead per channel.
- c. Stores all necessary parameters for channel signal reconstruction in real or scaled time.
- d. Preserves phase coherence between all channels for all rates (dc to maximum) and all types of channels.
- e. Accommodates variable and fixed rate primary channel of up to 256 Mbps.

6.5.1 Format Structure. General structure of the submux format is based on a constant block rate and variable block data length for each channel data block. The aggregate data stream is the sequential collection of each enabled channel data block with a three-word header. Each channel data block is the sequential collection of data samples or events within the block time period. A reserved channel (channel ID=31) provides frame synchronization and block timing and is always the first channel in the frame sequence. Individual channels can be enabled or disabled at any time within the rate limitations of the primary channel. Primary channel redundant parameter fields such as date, time, and annotation are placed in optional defined channel types, thereby, minimizing overhead caused by redundancy. All data and headers are bit packed into 16-bit words. All fields, unless specifically stated, are binary coded. Physical implementation of the format may have design restrictions as to types and quantities of channels and maximum allowable field limits.

6.5.2 Implied Parameters and Limits. Maximum aggregate rate (256 Mbps), block rate, first sample time delay measurement, and internal sample period are based on a 16-MHz clock rate divided by 2^N , where N can be set from 0 to 7 defining the derived clock. Block rate is based on the derived clock divided by 20 160 which sets the limit on the total aggregate word count of all channels in a block period. The maximum block rate (793.65 blocks per second) in conjunction with the 16-bit bit count field, limits the maximum subchannel input rate to 52 Mbps. The 16-MHz clock limits the time delay resolution to 62.5 nanoseconds.

The maximum number of channels is limited by the 5-bit field and the reserved block sync channel to 31 channels numbered from 0 to 30. Channel ID of 31 is the reserved block sync channel that conveys timing information. To accommodate fixed rate primary channel, fill can be inserted after the last channel data block, prior to the next block sync channel (at the end of the frame), and must consist of all binary ones (FFFF hex word value).

Channel priority is fixed in channel number sequence with channel ID of 31 (block sync) first, followed by channel ID 0, if enabled, to channel ID 30, followed by fill (if required) to maintain fixed channel rate. Any channel can be one of eight channel types. Type 0 channels convey timing data in the 3-word header and have implied data length of 0. Type other than zero contains the bit count field that defines the length of valid data in the data block. The actual word length of the data block is the integer of $\{(bit\ count + 15)/16\}$. Channel type also defines the content of the fields in the header.

6.5.3 Defined Parameters. Each channel data block has a 3-word (16-bit) header that contains the channel ID number, channel type, and other defined and undefined fields based on the channel type code. Undefined fields are reserved for future use and should be zero filled. Each channel header also contains up to 4 status bits that indicate the condition in the current data block or the condition of the last aggregate frame.

Channel ID 31 is a special form of channel type 0. The first two words are used for synchronization and are F8C7 BF1E hex value. The block rate clock (BRC) defines the main clock binary divider and is used for time scaled signal reconstruction. Each increment time period doubles. “Fill” indicates if the primary channel requires fill for fixed data rate.

Channel ID can be any unique number from 0 to 30 and designates the physical subchannel used for acquiring the data. Channel type defines the type of data this channel conveys and is currently defined for 0 to 5.

A type 0 “time tag” channel typically processes IRIG time code data and is used to time tag the frame. The Days Hours Minutes Seconds Fractional Seconds fields are the content of IRIG time code input or channel derived and in the same BCD form as the IRIG G time code.

Type nonzero headers contain FMT field that defines the format of the sample in bits per sample, 4-bit status field that indicates any errors or warnings pertaining to the current data block, bit count field that defines the length of valid data in the data block, and time delay field that (when external clock is used) indicates the delay from block time to the first sample in the BRC defined clock periods. When the internal clock is used, as indicated by type or most significant bit (MSB) of time delay, the sample period field defines the period of the internal sample clock in the BRC defined clock periods. The internal sample clock is always an integer divisor of the block period and the first sample is coincident with the block time. In type 1 blocks, this field is used for sequential block count.

When the internal clock is used with digital serial channel, the data and clock lines are sampled at the designated rate and result in eight data and eight clock samples per data block word. Otherwise, all incoming digital data are sampled at the incoming clock and results in a sample in the data block, with the first sample being left justified in the first word with “format” designated number of bits starting with the MSB of the sample. Samples are bit sequentially packed regardless of word boundaries. The last sample in the block period is fully packed into the current data block with the remaining portion of the word, if any, being left undefined.

6.5.4 Aggregate Format on the Primary Data Channel. Figure 6-5 shows the defined types of channel data from which the aggregate is composed. The primary data will always consist of the “frame sync” block followed by one or more unique channel blocks, followed by fill if required. The frame sync block will be generated at block rate. Aggregate data may be clocked by the primary channel or by the submux at constant or burst rate depending on the primary channel characteristics. Data format field definitions appear in Appendix G, Submux Data Format Field Definitions.

6.5.5 Submux/Demux FILL Requirement. The submux produces aggregate data at the user aggregate data rate. In other words, the rate and amount of data produced on the aggregate output is directly proportional to the user specified clock and data format bits and is averaged over the frame period. This variable aggregate data rate is acceptable to variable rate primary channels or buffered variable rate recorders.

Fixed rate primary channels and fixed rate recorders require data at some fixed rate. The fixed rate is usually set to be the maximum expected user aggregate rate. When the user aggregate rate is less than the maximum, then some sort of filler is necessary to maintain the constant output rate. The format-specified fill word provides this filler and is automatically generated when the primary channel or fixed rate recorder provides clocks after the last word of the last enabled channel is clocked out within the frame period. Fill is always terminated by the Frame of Block Sync channel, indicating the presence of the next frame data.

The quantity of fill words is totally dependent on the fixed primary channel rate and the average user aggregate rate within one frame period. Minimum is zero words when user rates are at the maximum and equal to the fixed rate (minus the overhead). When user rates are at the minimum, maximum amount of fill will be generated for maintaining constant output rate.

		16 BITS																	
		15	14	13	12	11	10	9	8	7	6	5	4	3	2	1	0		
GENERAL FORM	HW1	CHN ID				CHT				FMT				ST1	ST2	ST3	ST4		
	HW2																		
	HW3	I/E	TIME DELAY OR SAMPLE PERIOD																
FRAME SYNC	HW1	CHN ID = 1F				CHT = 0				SYNC 1 = F8C7 HEX (FULL WORD)									
	HW2	SYNC 2 = BF1E HEX																	
	HW3	BRC				FILL								AOE	PCR	ST3	ST4		
TIME TAG	HW1	CHN ID = 0 TO 30				CHT = 0				MSB DAYS (BCD)									
	HW2	DAYS				HOURS (BCD)				MINUTES (BCD)									
	HW3	SECONDS (BCD)																	
ANNOTATION TEXT	HW1	CHN ID = 0 TO 30				CHT = 1				FMT = 7				NC	OV R	PE	OE		
	HW2	BIT COUNT																	
	HW3	BLOCK COUNT																	
	DW1	MSB 1 ST CHARACTER								MSB 2 ND CHARACTER									
	:																		
	DWn	MSB LAST CHARACTER								UNDEFINED IF NOT LAST									
DIGITAL SERIAL EXTERNAL CLOCK	HW1	CHN ID = 0 TO 30				CHT = 2				FMT = 0				NSIB	OVR	ST3	ST4		
	HW2	BIT COUNT = L																	
	HW3	I/E= 0	TIME DELAY																
	DW1	DS ₁	DS ₂	DS ₃	DS ₄	DS ₅	DS ₆	DS ₇	DS ₈	DS ₉	DS ₁₀	DS ₁₁	DS ₁₂	DS ₁₃	DS ₁₄	DS ₁₅	DS ₁₆		
	:																		
	DWn									DS _{L-1}	DS _L	UNDEFINED IF NOT LAST							
DIGITAL SERIAL INTERNAL CLOCK	HW1	CHN ID = 0 TO 30				CHT = 2				FMT = 0				0	0	ST3	ST4		
	HW2	BIT COUNT = L																	
	HW3	I/E= 1	SAMPLE PERIOD																
	DW1	DS ₁	DS ₂	DS ₃	DS ₄	DS ₅	DS ₆	DS ₇	DS ₈	CS ₁	CS ₂	CS ₃	CS ₄	CS ₅	CS ₆	CS ₇	CS ₈		
	:																		
	DWn	DS _L	DS _L	DS _L	DS _L	DS _L	DS _L	DS _L	DS _L	DS _L	CS _L	CS _L	CS _L	CS _L	CS _L	CS _L	CS _L	CS _L	
DIGITAL PARALLEL EXTERNAL CLOCK	HW1	CHN ID = 0 TO 30				CHT = 3				FMT = 0-15 (shown=6)				NSIB	OVR	ST3	ST4		
	HW2	BIT COUNT = L																	
	HW3	I/E= 0	TIME DELAY																
	DW1	MSB 1 ST SAMPLE								MSB 2 ND SAMPLE								3 RD SAMPLE	
	:																		
	DWn	MSB LAST SAMPLE								LSB=BIT L								UNDEFINED IF NOT LAST	
ANALOG WIDE BAND	HW1	CHN ID = 0 TO 30				CHT = 4				FMT = 0-15 (shown=7)				AOR	ST2	ST3	ST4		
	HW2	BIT COUNT = L																	
	HW3	I/E= 1	SAMPLE PERIOD																
	DW1	MSB 1 ST SAMPLE								MSB 2 ND SAMPLE									
	:																		
	DWn	MSB LAST SAMPLE								UNDEFINED IF NOT LAST									
ANALOG STEREO "L" & "R"	HW1	CHN ID = 0 TO 30				CHT = 5				FMT = 0-15 (shown=7)				LAO R	RAO R	ST3	ST4		
	HW2	BIT COUNT = L																	
	HW3	I/E= 1	ENL	ENR	SAMPLE PERIOD														
	DW1	MSB 1 ST SAMPLE "L"								MSB 1 ST SAMPLE "R"									
	:																		
	DWn	MSB LAST SAMPLE								UNDEFINED IF NOT LAST									
FILL	FW	FILL WORD — FFFF HEX																	

Figure 6-5. Submux data format.

6.6 1/2 Inch Digital Cassette (S-VHS) Helical Scan Recording Standards

These standards are for helical scan digital magnetic tape recorder/reproducers using the very large data store (VLDS) format. This standard is intended for applications where compact size is needed and bit rates do not exceed 32 or 64 megabits per second (Mbps). The VLDS is a 12.65 mm (1/2 inch) S-VHS (850 Oersteds nominal) media based tape format. This standard describes the salient features of the LDS format. To ensure crossplay compatibility between recorders of different manufacturers, refer to Metrum-Datatape document number and title 16829019, M64/32HE Magnetic Tape Recorder/Reproducer Tape Format Specification.

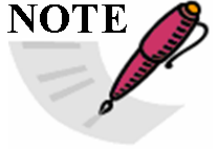
 <p>NOTE</p>	<p>Metrum-Datatape is now Sypris Data Systems and this specification may be updated in the near future to reflect this change in name. An Adobe pdf copy of this specification can be obtained by calling (303) 773-4701. Many of the specifications listed in this chapter have been adapted from this document.</p>
--	---

6.6.1 Magnetic Tape and Cassettes. The magnetic tape shall meet the requirements of Magnetic Media Laboratory (MML) Document 93-1, Specification for Rotary Instrumentation Magnetic Recording Tape, 12.65 millimeter (0.5 inch), 68 KA/M (850 Oersteds)⁴. The tape cartridge shall conform to ANSI Standard V98.33M-1983, Specification for Physical Characteristics and Dimensions⁵. To ensure crossplay compatibility, the T-160 (327 meters, min.) is recommended.

6.6.2 Format Types. There are four standard formats. Two B formats provide 32 Mbps standard density or 64 Mbps high density for most applications where severe environmental conditions are not encountered. There are also two E formats provide 16 Mbps standard density or 32 Mbps high density for harsh environments involving extremes of vibration and temperature. A tape made on a standard density system may be reproduced on a high density system. Relative to the B formats, the E formats use a 100 percent larger track pitch, an 81 percent larger track width, and a larger guard band providing a very large margin for accurately tracking and recovering data under extreme conditions. The E formats provide only about one-half the data storage capacity of the B format but can be played back on a B format system.

⁴ MML Document 93-1 is available from the Naval Air Warfare Center Aircraft Division, Patuxent River, Maryland 20670.

⁵ ANSI V98.33M-1983 is available from the American National Standards Institute, 1430 Broadway, New York, New York 10018.

6.6.2.1 B Format. These formats originate from helical scanner implementations using four helical heads organized in pairs at 180° separation. The heads are both read and write functionally and are supported by two parallel sets of read/write electronics referred to as data channels. Helical track dimensions are given in Figure 6-6.

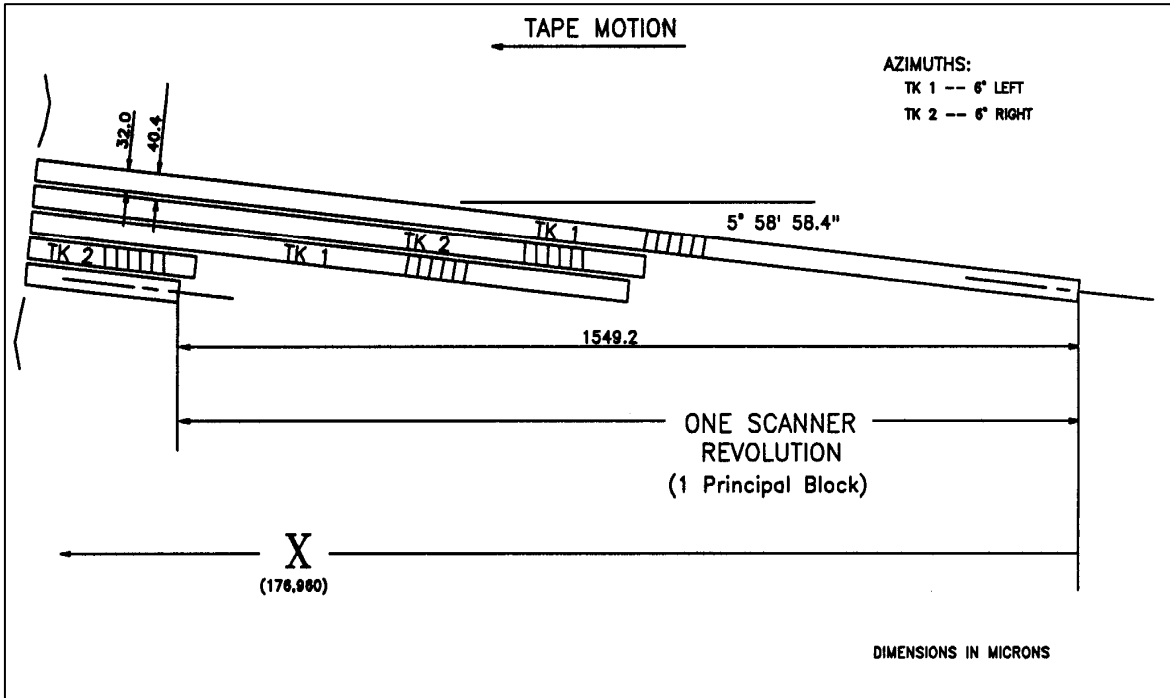

Figure 6-6. Helical track dimensions, B format.

6.6.2.2 E Format. These formats originate from helical scanner implementations using two helical heads with wider track widths at 180° separation on the scanner. The heads are both read and write functionally. One set of read/write or write only electronics is required. Helical track dimensions are given in Figure 6-7.

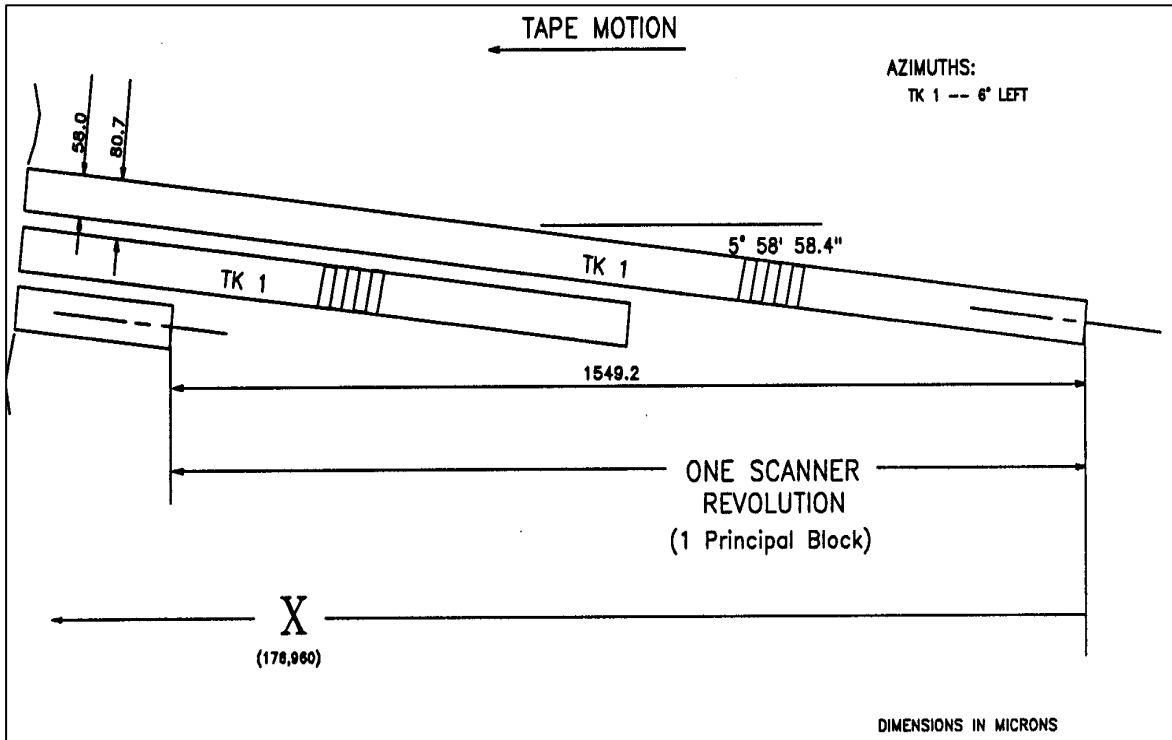

Figure 6-7. Helical track dimensions, E format.

6.6.3 Data Storage. Data are recorded onto 12.65 mm (1/2 in.) wide magnetic tape using both rotating and fixed heads (see Figure 6-9). The rotating heads record data in adjacent track patterns at an inclined angle to the normal tape motion. The fixed heads record data on tracks parallel to the tape motion. The fixed head tracks are used for control and servo purposes and do not directly record user data.

6.6.4 Physical Relationships. Maintaining high accuracy of the ratio between scanner rotational speed and tape speed (1.5492 mm (0.0610 in.) of tape motion per scanner rotation) is critical to maintaining the format geometry. Head and tape speed will vary accordingly with changes in the other two speed parameters. The three speed parameters vary linearly with desired user data rates. Parameters used with a user data rate of 32 Mbps (B) or 16 Mbps (E) are as follows in Table 6-4:

TABLE 6-4. PHYSICAL PARAMETERS	
user bits/helical track	$2^{17} = 131\,072$ bits (16 kilobytes)
scanner diameter	62.000 mm + 0.008/-0.000 mm (2.44 in. + 0.0003 in.)
scanner rotation speed	3662.1 rpm
tape speed	94.55 mm/sec (3.72 in./sec.)
head/tape speed	11 794.30 mm/sec (464.34 in./sec.)
helix angle (head rotational plane to ref. edge of tape)	$5^{\circ} 56' 7.4''$ basic dimension
head gap length	refer to Metrum Document 16829019 ⁶
tape tension (inlet side of scanner)	$0.35\text{N} \pm 0.02\text{N}$

6.6.5 Helical Track Organization. Each group of four helical tracks resulting from one complete revolution of the scanner (two helical tracks for the E formats) is termed a principal block on the tape. A principal block is the smallest increment of data that may be written to or read from the tape. Each principal block is assigned a unique number, which is recorded as part of the helical track. Helical tracks containing user data begin with the number 1 and are sequentially incremented on the tape up to the capacity of the cartridge. Whenever new data are appended on a previously recorded cartridge, the new data are precisely located to begin with the next helical track location after the previous end of data point with no interruption or discontinuity in track spacing.

6.6.6 Recorded Information. The following subparagraphs contain additional information.

6.6.6.1 Add overhead bytes generated by error correction encoding algorithms.

6.6.6.2 Provide preamble and postamble patterns for isolation of the information at the beginning and end of the helical tracks.

6.6.6.3 Provide clock synchronization patterns to facilitate clock recovery at the beginning of each helical track.

6.6.6.4 Add patterns throughout the helical track to maintain synchronization and counteract bit slips during data extraction.

6.6.6.5 Provide redundantly recorded principal block numbers for organizing data on the cartridge.

6.6.6.6 Include a user specifiable volume label for identifying the entire cartridge.

⁶ See reference on how to obtain the Metrum-Datatape document at paragraph 6.6 above.

6.6.6.7 Add miscellaneous data used to convey information about the organization of data on the cartridge and within the helical tracks.

6.6.7 Recording Geometry and Physical Dimensions. Included in the following subparagraph are the recording geometry and the physical dimensions.

6.6.7.1 Tape Reference Edge. The tape reference edge for dimensions specified in this section shall be the lower edge as shown in Figure 6-8. The magnetic coating, with the direction of tape travel as shown in Figure 6-6, shall be the side facing the observer.

6.6.7.2 Helical Tracks. Contained in the succeeding subparagraphs are the helical tracks attributes.

6.6.7.2.1 Track Widths. The width of a written track shall be 0.032 mm \pm 0.002 (0.0013 in. \pm 0.000079) for the B formats and 0.058 mm \pm 0.002 (0.0023 in. \pm 0.000079) for the E formats.

6.6.7.2.2 Track Pitch. The distance between the center lines of any two adjacent tracks, measured perpendicular to the track length, shall be 0.0404 mm (0.0016 in.) for the B formats and 0.0808 mm (0.0032 in.) for the E formats.

6.6.7.2.3 Track Straightness. Either edge of the recorded track shall be contained within two parallel straight lines 0.005 mm (0.0002 in.) apart. The center lines of any four consecutive tracks shall be contained within the pattern of four tolerance zones. Each tolerance zone is defined by two parallel lines, which are inclined at an angle of 5° 58' 58.4" basic with respect to the tape edge. The center lines of the tolerance zones shall be spaced 0.0404 mm (0.0016 in.) apart for the B format and 0.0808 mm (0.0032) apart for the E format. The width of the first tolerance zone shall be 0.007 mm (0.00028 in.). The width of tolerance zones two, three, and four shall be 0.011 mm (0.0004 in.). These tolerance zones are established to contain track angle, straightness, and pitch errors.

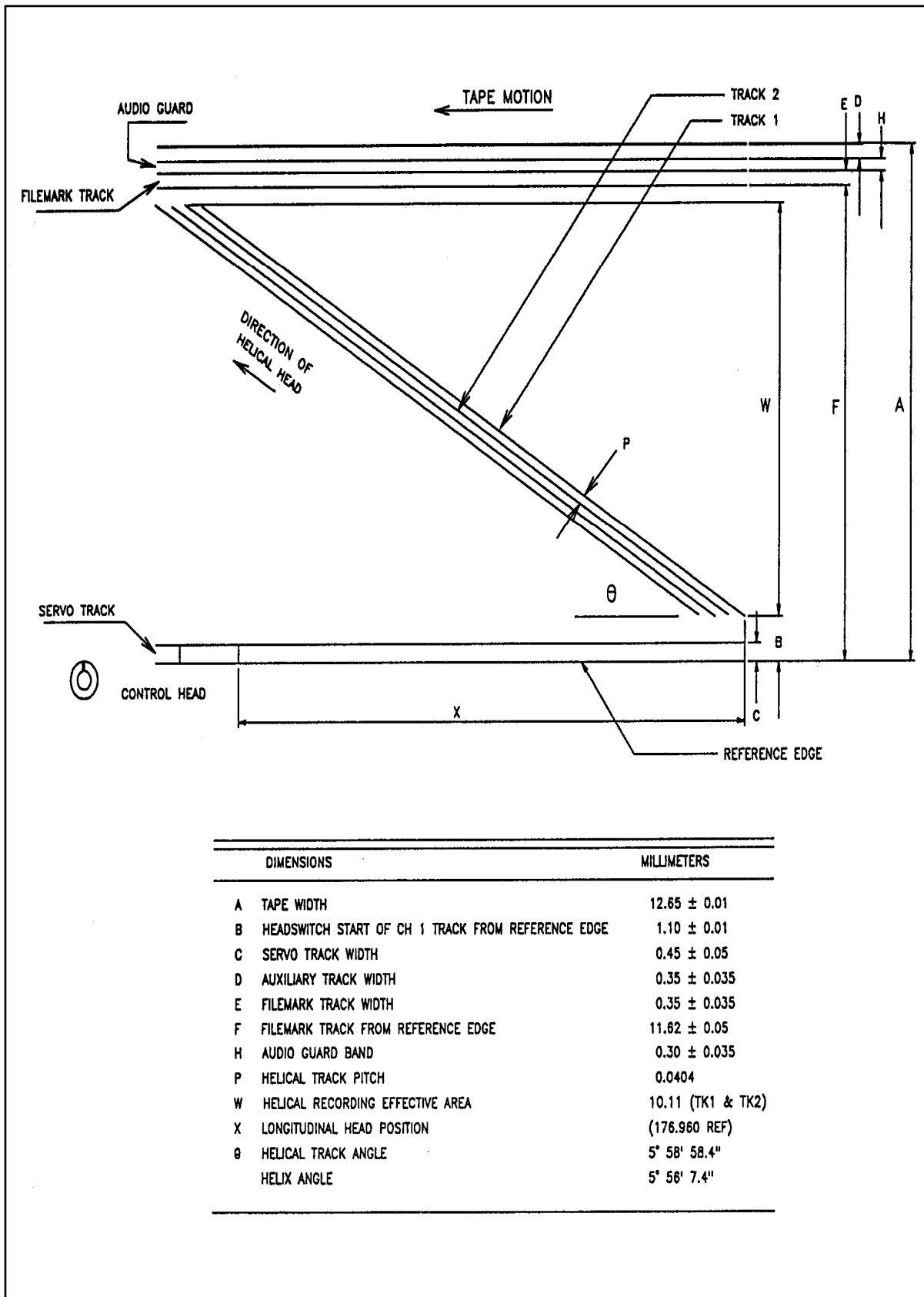

Figure 6-8. Recorded tracks on tape, B format.

6.6.7.2.4 Gap Azimuths. The azimuth of the head gaps used for the helical track recording shall be inclined at angles of $\pm 6^\circ \pm 15'$ to the perpendicular to the helical track record (see Figure 6-8 and Figure 6-9). For the E formats and for the first and third tracks of every principal block of the B formats, the recorded azimuth is oriented in the clockwise direction with respect to the line perpendicular to the track direction when viewed from the magnetic coating side of the tape. For the B formats, the second and fourth tracks of each principal block are oriented in the counterclockwise direction.

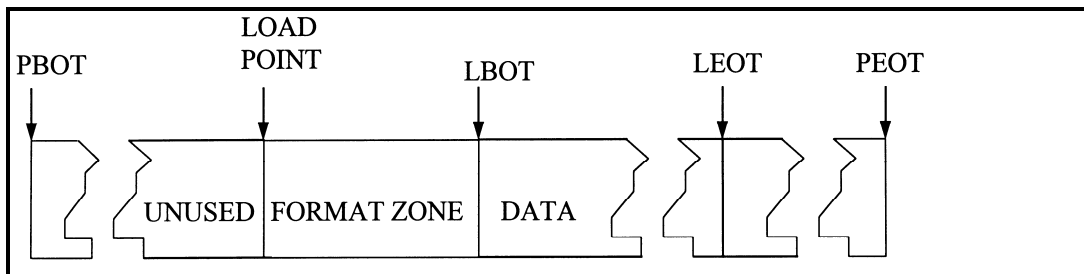

Figure 6-9. Tape cartridge layout.

6.6.7.2.5 Track Guard Bands. The nominal unrecorded guard band between any two adjacent helical tracks shall be 0.008368 mm (0.0003 in.) for the B formats and 0.022737 mm (0.0009 in.) for the E formats.

6.6.7.2.6 Track Angle. The track angle shall be $5^\circ 58' 58.4''$.

6.6.7.2.7 Track Length. The track length shall be 96.619 mm (3.80 in.).

6.6.7.2.8 Physical Recording Density. The maximum physical density of the recording shall be 1930 or 3776 flux transistors per millimeter (ftpm) respectively for the 32 and 64 Mbps systems.

6.6.7.3 Longitudinal Tracks. The characteristics of the longitudinal tracks are described in the subsequent subparagraphs.

6.6.7.3.1 Servo Track. The servo track is located along the reference edge of the tape as shown in Figure 6-7. The azimuth angle of the servo track head gap shall be perpendicular to the recorded track. The recording of the servo track is composed of a recorded pulse (nominally 0.0185 mm (0.0007 in.)) for each principal block on the tape. The recording shall achieve full magnetic saturation for at least half the pulse. The time duration of the pulse is determined by the tape speed to yield this physical dimension. During the interval between pulses, no magnetic recording occurs on the track. The pulse is timed to begin coincident with the midpoint of the principal block (the data channel switches from first to second head). The physical offset from the longitudinal head to the helical heads is shown in Figure 6-7, Figure 6-8, and Figure 6-9 as dimension "X."

6.6.7.3.2 Filemark Track. The filemark track is located near the top of the tape as shown in Figure 6-7. The azimuth angle of the filemark track head gap shall be perpendicular to the recorded track. The recording of the filemark track is composed of a series of pulses located in

conjunction with the principal block to be marked. Each filemark is composed of three redundant pulses (nominal 0.005 mm (0.0002 in.)). The three pulses are typically spaced 0.029 mm (0.0011 in.) apart with a maximum span of 0.09 mm (0.0035 in.) from the beginning of the first to the beginning of the third. This triplet of pulses is for redundancy against tape flaws and on detection are treated as one filemark regardless of whether 1, 2, or 3 pulses are detected. The filemark pulses are associated with a specific principal block by initiating the first pulse between 4 to 5.5 msec after the midpoint of the principal block. (Data channel switches from first to second head.)

6.6.8 Tape Cartridge Format. The physical format of the recording along the length of the tape is shown in Figure [6-10](#). Immediately following the physical beginning of tape (PBOT) is an unused portion of tape, followed by the cassette format zone, which precedes the logical beginning of tape (LBOT). Principal blocks of user data shall be recorded between LBOT and the logical end of tape (LEOT), which precedes the physical end of tape (PEOT).

6.6.8.1 Load Point. The load point is defined as the first point after PBOT accessible by the recording system with the tape fully engaged to the scanner.

6.6.8.2 Format Zone. The format zone begins at the load point, precedes the LBOT, and consists of a minimum of 450 principal blocks recorded on the tape. It provides a run up area for the servo systems and principal block identification allowing precise location of the LBOT where user data begin. The zone must be prerecorded to prepare the cartridge to accept user data. This process involves locating at the load point and beginning recording as soon as tape speed servo lock is achieved. The principal blocks recorded are numbered beginning with a negative number and counting up until principal block 0 is recorded. Principal block 0 shall be the last recorded block in the format zone. Principal blocks recorded in the format zone do not contain user data or error correction coding (ECC) overhead bytes, but do contain the remaining miscellaneous information described in paragraph [6.6.6](#) and in the helical track data format descriptions. The volume label for the cartridge is irreversibly determined at the time the format zone is recorded.

6.6.8.3 Logical Beginning of Tape. The logical beginning of tape denotes the end of the format zone and the point at which principal blocks containing reproducible data begin. The first principal block containing useful information shall be assigned the number one.

6.6.8.3 Data Zone. Beginning with principal block 1 at LBOT and continuing through to LEOT, the data zone shall be the principal blocks that record user data as well as the added miscellaneous information to allow full reproduction and management of the data on the tape cartridge.

6.6.8.5 Logical End of Tape. The logical end of tape is a physical principal block count. The principal block count for the standard ST-160 tape cartridge is 210 333.

6.6.9 Helical Track Format. The format for writing data into a single helical track is shown in Figure [6-11](#). The term "bits" refers to actual on tape bit cells. Each helical track begins with a preamble area consisting of 6216 bits of an alternating pattern of three 0 bits and three 1 bits for

the 32 Mbps system or 9240 bits for the 64 Mbps system. This 6-bit pattern is repeated 1036 or 1540 times. The preamble is followed by a track synchronization area. This area provides for obtaining registration to the track data patterns. It is composed of four zones of 732 bits each with an alternating 0- and 1-bit pattern that facilitates clock recovery. Each of these four zones is followed by a 36-bit sync pattern. These sync patterns are described more fully in paragraph [6.6.9.1](#). The track synchronization area ends with 24 bits of an alternating pattern of three 0 bits and three 1 bits. The central area is where actual user data are recorded in 138 data blocks for the 32 Mbps system or 276 data blocks for the 64 Mbps system. Each data block contains $205 \frac{5}{6}$ modulation code frames of interleave data for a total of 1230 bits.

This data is followed by a 36-bit sync pattern. Sync patterns and interleave data are more fully described next. Each helical track ends with a postamble pattern of three 0 bits and three 1 bits. This is the same pattern as the preamble. Compiling all bits yields an overall track total of 186 468 tape bits for the 32 Mbps system and 364 824 tape bits for the 64 Mbps system. Since each contains 131 072 or 262 144 user bits, overheads are 29.7 and 28.1 percent.

6.6.9.1 Sync Patterns. Each helical track contains 142 or 280 sync patterns as shown in Figure [6-10](#). Four of these are contained in the track sync area with the remaining 138 or 276 distributed at the end of each data block. These sync patterns provide registration to the bit sequence and allow management of bit slips. The track and data sync consists of 36 bits in the form of six 6-bit words. The first five words are the same for all sync words (Table [6-5](#)).

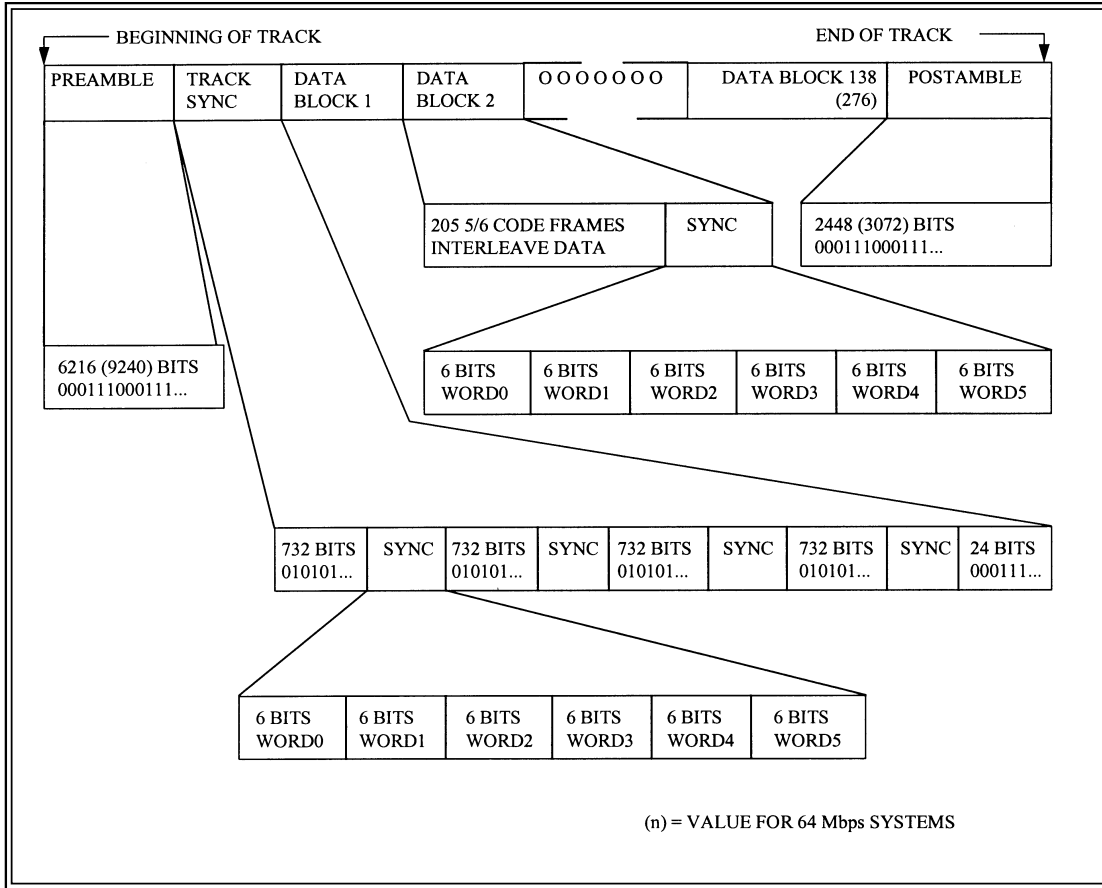

Figure 6-10. Helical track format.

TABLE 6-5. TRACK AND DATA SYNC: WORD 0-WORD 4	
WORD0	2A _h
WORD1	2A _h
WORD2	0C _h
WORD3	0F _h
WORD4	21 _h

WORD5 defines which sync word is being issued in the following manner (Table 6-6).

TABLE 6-6. TRACK AND DATA SYNC: WORD 5	
Sync Loc.	Word
Track Sync 1	39 _h
Track Sync 2	35 _h
Track Sync 3	2D _h
Track Sync 4	1D _h
Data Sync 1	2B _h
Data Sync 2	2E _h
Data Sync 3	2B _h
Data Sync 4	2E _h
Data Sync 5	2B _h
Data Sync 6	2E _h
:	:
Data Sync 279	2B _h
Data Sync 280	2E _h

6.6.9.2 Data Blocks. Each helical track contains 138 or 276 data blocks, which record the user data as well as miscellaneous information used in locating and managing data on the tape cartridge (see Figure 6-10). The construction of these data blocks is performed by each channel's data path electronics. Figure 6-11 illustrates a typical block diagram of a channel data path as described in the following subparagraphs.

6.6.9.2.1 Error Correction Encoding. An interleaved Reed-Solomon (RS) code is used for error detection and correction. An outer ECC is applied to written data first which is an RS (130, 128) for purposes of error detection only. An inner ECC is subsequently applied which is an RS (69, 65) for error detection and correction. The resulting encoded data is stored in a multiple page interleave buffer memory array containing 128 rows by (2•69) or (8•69) columns of encoded user data. For the outer ECC, incoming data is arranged in groups of 128 bytes each. The outer ECC encoder appends 2 check bytes to each 128 byte block. For the inner ECC, the 130 byte group resulting from the outer ECC is divided into two 65 byte blocks. The first 65 byte block (ECC code words 1, 3, 5, ...) contains all user data while the second 65 byte block (ECC code words 2, 4, 6, ...) contains 63 bytes of user data with the last 2 bytes being the check bytes generated by the outer ECC. The inner ECC encoder appends 4 check bytes to each 65 byte block.

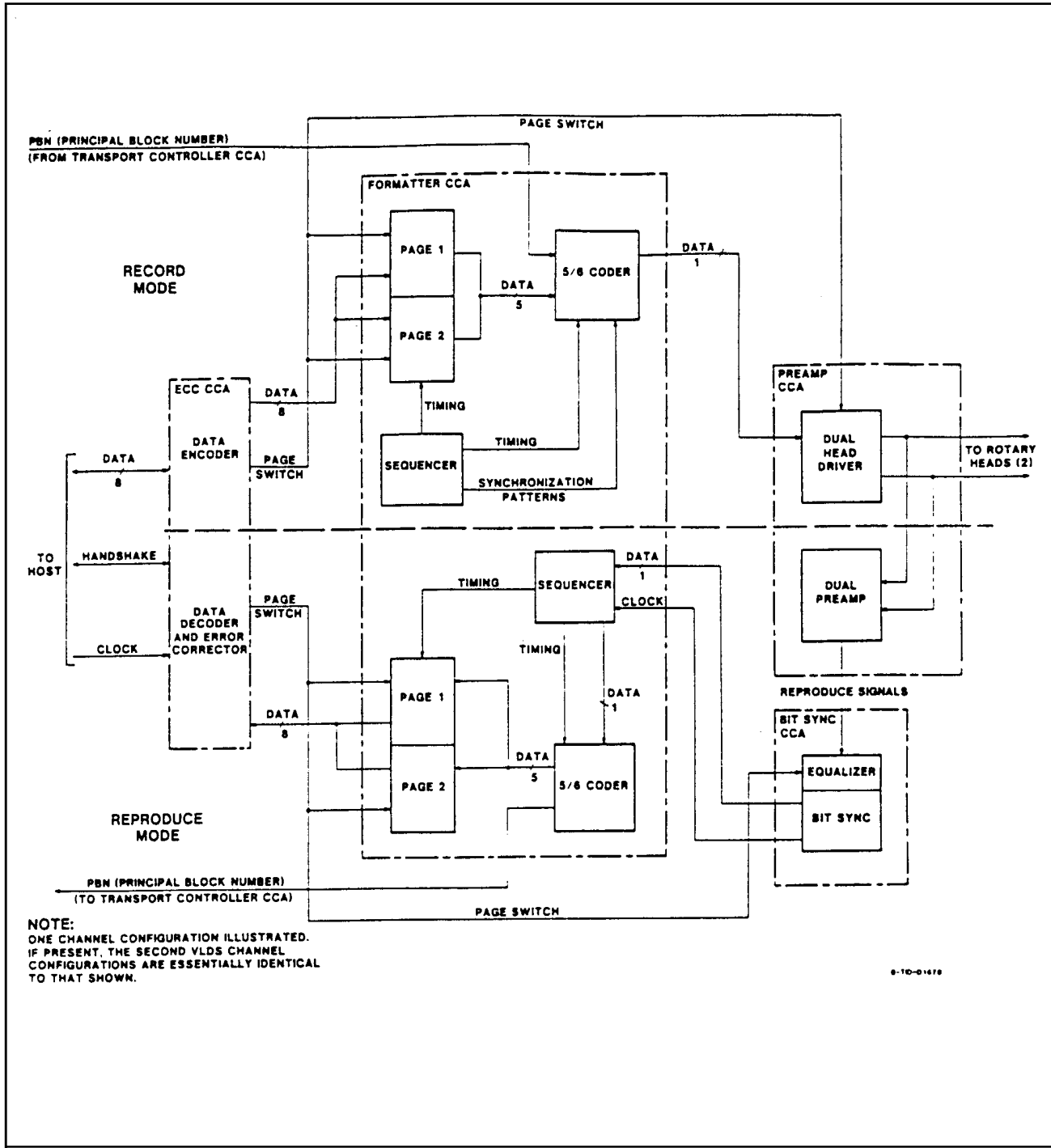

Figure 6-11. Typical VLDS data path electronics block diagram.

Operations in the RS encoder are performed using numbers in a finite field (also called a Galois field (GF)). The field used contains 256 8-bit elements and is denoted GF (256). The representation of GF (256) used is generated by the binary degree eight primitive polynomials.

$$p(x) = x^8 + x^4 + x^3 + x^2 + 1 \quad \text{outer ECC}$$

$$p(x) = x^8 + x^5 + x^3 + x + 1 \quad \text{inner ECC}$$

The ECC generator polynomials are:

$$G(x) = (x+a^{24})(x+a^{25}) \quad \text{outer ECC}$$

$$G(x) = (x+1)(x+a)(x+a^2)(x+a^3) \quad \text{inner ECC}$$

where "a" denotes the primitive element of the field.

6.6.9.2.2 Interleave Buffer. Encoding data from the two levels of ECC are stored in an interleave buffer memory. The architectures for this memory are shown in Figure 6-12. This buffer allows interleaving of the encoder data. Interleaving spreads adjacent ECC code word bytes within a helical track for the 32 Mbps system to minimize the effect of burst error events. For the 64 Mbps system, interleaving spreads adjacent ECC code word bytes within two helical tracks (two helical tracks per channel per principal block) to further minimize burst error effects. Data to and from the ECC are accessed along horizontal rows in the memory matrix. Data to and from tape are accessed along vertical columns in the memory. Each column in the matrix consists of 128 bytes that will constitute one block in the helical track format (see Figure 6-11).

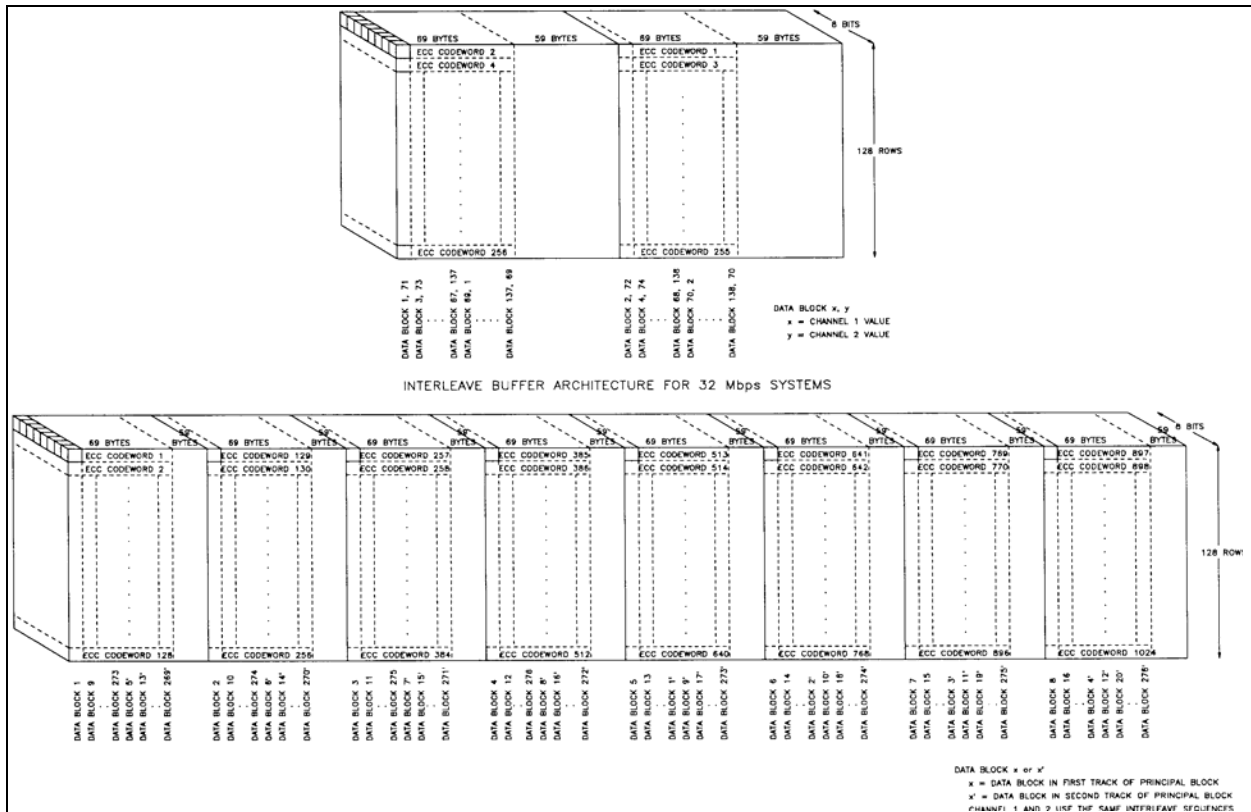

Figure 6-12. Interleave buffer architectures.

6.6.9.2.2.1 Exchange of Data with ECC. Addressing of the interleave buffer for exchange of data with the ECC for the 32 Mbps systems is as follows in Table 6-7.

TABLE 6-7. ECC - INTERLEAVE BUFFER ADDRESSING (32 Mbps)	
ECC Code Word	Address Range (hex)
1	0080 to 00C4
2	0000 to 0044
3	0180 to 01C4
4	0100 to 0144
5	0380 to 03C4
6	0200 to 0244
:	:
253	7E80 to 7EC4
254	7E00 to 7E44
255	7F80 to 7FC4
256	7F00 to 7F44

Addressing of the interleave buffer for exchange of data with the ECC for the 64 Mbps systems is as follows in Table 6-8.

TABLE 6-8. ECC - INTERLEAVE BUFFER ADDRESSING (64 Mbps)	
ECC Code Word	Address Range (hex)
1	00000 to 00044
2	00400 to 00444
3	00800 to 00844
:	:
128	1FC00 to 1FC44
129	00080 to 000C4
130	00480 to 004C4
:	:
256	1FC80 to 1FCC4
257	00100 to 00144
258	00500 to 00544
:	:
512	1FD80 to 1FDC4
513	00200 to 00244
514	00600 to 00644
:	:
1024	1FF80 to 1FFC4

Note: Each code word is 69 bytes long. The address increments by hex 001 for each byte in a code word. The first data byte sent to/from the ECC for each helical track is stored in location 000.

6.6.9.2.2.2 Exchange of Data To and From Tape. Addressing of the interleave buffer for exchange of data to and from tape for the 32 Mbps system is as follows in Table 6-9.

TABLE 6-9. TAPE - INTERLEAVE BUFFER ADDRESSING (32 Mbps)		
Data Block	Address Range (Channel 1)	Address Range (Channel 2)
1	0000 to 7F00	0022 to 7F22
2	0080 to 7F80	00A2 to 7FA2
3	0001 to 7F01	0023 to 7F23
4	0081 to 7F81	00A3 to 7FA3
5	0002 to 7F02	0024 to 7F24
6	0082 to 7F82	00A4 to 7FA4
:	:	:
67	0021 to 7F21	0043 to 7F43
68	00A1 to 7FA1	00C3 to 7FC3
69	0022 to 7F22	0044 to 7F44
70	00A2 to 7FA2	00C4 to 7FC4
71	0023 to 7F23	0000 to 7F00
:	:	:
135	0043 to 7F43	0020 to 7F20
136	00C3 to 7FC3	00A0 to 7FA0
137	0044 to 7F44	0021 to 7F21
138	00C4 to 7FC4	00A1 to 7FA1
<u>Note:</u> Each data block is 128 bytes long. The address increments by hex 0100 for each byte in a data block. The first byte sent to/from tape for each channel 1 helical track is stored in location 0000. The first byte sent to/from tape for each channel 2 helical track is stored in location 0022.		

Addressing of the interleave buffer for exchange of data to/from the 64 Mbps system is as follows in Table [6-10](#).

6.6.9.2.3 8 to 5 Conversion. Data being moved from the interleave buffer to tape is read from the memory in 8-bit bytes and is immediately converted to 5-bit groups in preparation for modulation coding. During reproduction, this conversion occurs in reverse fashion. The algorithm for conversion is detailed in Metrum Specification 16829019.⁷

⁷ See reference on how to obtain the Metrum-Datatape document at paragraph [6.6](#) above.

TABLE 6-10. TAPE - INTERLEAVE BUFFER ADDRESSING (64 Mbps)

Data Block	Address Range (hex)
1	00000 to 1FC00
2	00080 to 1FC80
3	00100 to 1FD00
4	00180 to 1FD80
:	:
8	00380 to 1FF80
9	00001 to 1FC01
10	00081 to 1FC81
:	:
275	00122 to 1FD22
276	001A2 to 1FDA2
1'	00222 to 1FE22
2'	002A2 to 1FEA2
3'	00322 to 1FF22
:	:
8'	01A3 to 1FDA3
9'	00223 to 1FE23
10'	002A3 to 1FEA3
:	:
275'	00344 to 1FF44
276'	003A4 to 1FFA4

Note: Each data block is 128 bytes long. The address increments by hex 0400 for each byte in a data block. The first byte sent to or from tape for both channels is stored in location 00000. The interleave buffer extends across both helical tracks in a principal block for each channel, thus the data block number “n” refers to the data block in the first helical track of the principal block and the data block number “n’ ” denotes the data block number in the second helical track of the principal block.

6.6.9.2.4 **Miscellaneous Information Inclusion.** Each data block in the helical track includes one additional bit added to the data set prior to modulation coding. Each data block removed from the interleaved buffer memory consists of 128 bytes of ECC encoded user data totaling 1024 bits. Conversion from 8-bit bytes to 5-bit groups results in 204 groups plus 4 bits. A miscellaneous information bit is added to each data block as the 1025th bit to complete 205 full 5-bit groups. Miscellaneous information is currently defined only in the first helical track of each principal block. The remaining three helical tracks (1 in the E format) contain no defined miscellaneous bits and are reserved for future expansion. Any reserved miscellaneous information bits shall be recorded as 0 bits. The defined purposes of miscellaneous information bits in the first helical track of each principal block are presented in Table [6-11](#).

TABLE 6-11. MISCELLANEOUS BIT DEFINITIONS

Data Block	Miscellaneous Bit Definition
1 to 20 inclusive	First copy of 20-bit principal block number: 2s complement binary; least significant bit in data block 1; most significant bit in data block 20.
21 to 40 inclusive	Second copy of 20-bit principal block number: 2s complement binary; least significant bit in data block 21; most significant bit in data block 40.
41 to 60 inclusive	Third copy of 20-bit principal block number: 2s complement binary; least significant bit in data block 41; most significant bit in data block 60.
61 to 76 inclusive	Volume label: 16-bit binary; least significant bit in data block 61; most significant bit in data block 76.
77 to 80 inclusive	Revision number: 4-bit code; value at time of writing is 0001 (1 _h).
81 to 84 inclusive	4-bit tape information code as follows:
81 bit =	0 denotes all helical data was input as user digital data.
81 bit =	1 denotes input data stream to each channel. The ECC was 15 bytes of user digital data beginning with first byte plus 1 inserted byte from a different source in a repeating fashion. This bit must be uniformly set for the entire cartridge including the format zone. It is used to support mixing of digitized analog data into the digital stream and separation on reproduction.
82 bit =	0 denotes cartridge size is ST-120 for purposes of determining LEOT. This bit must be set for the entire cartridge including the format zone.
82 bit =	1 denotes cartridge size is ST-160 for purposes of determining LEOT. This bit must be set uniformly for the entire cartridge including the format zone.
83 bit =	Reserved for additional tape information coding.
84 bit =	Reserved for additional tape information coding.
85 to 138 or 276 inclusive	Reserved for future expansion.

6.6.9.2.5 **Modulation Code.** Data is encoded using a 5/6 modulation code that has a spectral null at dc. The coding algorithm employed has a code word digital sum (CWDS) maximum of ± 2 with a maximum run length of 6 bits. The 205 5-bit groups resulting from the 8 to 5 conversion (including the inserted miscellaneous bit) undergo this coding to form the final 5/6 code frames that are physically recorded in the data blocks of the helical track format. The algorithm for coding is detailed in Metrum Specification 16829019.

6.7 Multiplex/Demultiplex (MUX/DEMUX) Standards for Multiple Data Channel Recording on 1/2 Inch Digital Cassette (S-VHS) Helical Scan Recorder/Reproducer Systems

For recording and reproducing multiple channels on 1/2 inch digital cassette (S-VHS) helical scan recorders, the asynchronous real-time multiplexer and output reconstructor (ARMOR) multiplex/demultiplex format is recommended. The ARMOR data format is an encoding scheme that may be used to multiplex multiple asynchronous telemetry data channels into a single composite channel for digital recording, transmission, and subsequent demultiplexing into the original constituent channels.

6.7.1 General. Data types supported by the ARMOR format are PCM, analog, decoded IRIG time, and 8-bit parallel. MIL-STD-1553B⁸ data is encoded into an IRIG 106 Chapter 8 serial PCM stream prior to multiplexing into the ARMOR format. Voice channels are encoded in the same way as all other analog channels. The composite channel is formatted into fixed bit-length, variable word-length frames. A constant aggregate bit rate and a fixed frame bit-length are established for each multiplex by an algorithm that is dependent on the number, type, and rate of the input channels. The aggregate bit rate and frame bit length result in a fixed frame rate for each multiplex. The ARMOR encoding scheme captures the phase of each input channel relative to the start of each composite frame. The demultiplexing process may then use the captured phase information to align the reconstruction of the constituent channels relative to a reproduced constant frame rate.

6.7.2 Setup Block Format. In addition to defining the organization of the frames containing the multiplexed data, the ARMOR format incorporates the definition of a “setup block” that contains the parameters necessary to demultiplex the associated data frames. The setup block is included in the composite stream at the start of each recording to preserve with the data the information necessary to decode the data. Appendix L defines the setup block format and content.

6.7.3 Multiplexer Format. The definition of the ARMOR multiplex format has two parts. The frame structure definition describes the organization of the composite data frame, which changes from one multiplex to the next. The channel coding definition describes the encoded data word format for each data type, which is the same for all multiplexers.

6.7.3.1 Frame Structure. The sequence of steps used to establish the multiplexed frame structure, shown in Figure 6-13 below, is explained in Table 6-12. The process involves putting the sync, PCM, parallel (PAR), time code, and analog channels into a frame. The filler blocks may consist of either constant (hex FF) bytes or analog samples, depending upon the constituent input channel mix. The PCM Sample Start Bit Point and the Parallel Sample Start Bit Point are based on calculations of the master oscillator, pacer, and the bit rate of the slowest PCM and word rate of the slowest parallel channels respectively. The pacer is a clock pulse that is programmed to a multiple of the fastest analog channel sample rate. These calculations assure that the first word of the slowest PCM channel or the first word of the slowest parallel channel is not placed too early in the composite frame. If necessary to satisfy these Start Bit Point calculations, filler in the form of analog channel words or hex FF (if no analog words are available) is used to force the first PCM or PAR word later in the composite frame. Compatibility with specific legacy

⁸ MIL-STD 1553B (1996), Digital Time Division Command/Response Multiplex Data Bus.

versions of the format requires the use of the appropriate equations, which are embodied in a software program, refer to Calculex Part No. 199034-0002.⁹

Step 1				2	3	4				5	6				7		
1	2	3	4			1	2	...	m			1	2	...	m		
Sync				Filler		PCM Channel Blocks				Filler		PAR Channel Blocks				Filler	

Figure 6-13. The steps of the build process.

⁹ Part Number 199034-0002, available from CALCULEX, Inc., P.O. Box 339, Las Cruces, NM 88004 (505) 525-0131 or by email to info@calculex.com.

TABLE 6-12. SCANLIST BUILD STEPS

(Reference scanlist in Figure 6-13)		
Step #1	Sync	The sync is made up of four bytes of 8 bits totaling 32 bits: FE 6B 28 40.
Step #2	Time Code	If time code exists, it is placed after the sync in three words of bit length 24, 24, and 16. Multiple time codes are placed in ascending hardware sequence, as identified in the setup block.
Step #3	Filler (PCM Start Bit)	If required, either filler or analog channels are placed next, depending on the calculation of the PCM Sample Start Bit Point. If no analog (or voice) channels are included in the multiplex, hex value "FF" filler is inserted in the frame as required to satisfy the PCM Sample Start Bit Point calculation. When analog channels are part of the multiplex, analog words are used in place of hex FF filler to minimize the formatting overhead.
Step #4	PCM Channels	The PCM channels are placed next in ascending order of speed with the slowest channel first. Multiple channels at the same speed are placed in ascending hardware sequence, as identified in the setup block.
Step #5	Filler (PAR Start Bit)	If required, either filler or analog channels are placed next, depending on the calculation of the PAR Sample Start Bit Point. If no analog (or voice) channels are included in the multiplex, hex FF filler is inserted in the frame as required to satisfy the PAR Sample Start Bit Point calculation. When analog channels are part of the multiplex, any remaining analog words that were not inserted in the frame at step 3 are used in place of hex FF filler to minimize the formatting overhead channel.
Step #6	PAR Channels	The PAR channels are placed next in ascending order of speed with the slowest channel first. Multiple channels at the same speed are placed in ascending hardware sequence, as identified in the setup block.
Step #7	Filler (Analog Channels)	All remaining analog words that have not been used for filler in steps 3 and 5 are placed next, followed by any additional filler required to satisfy the pacer divisor calculation.

6.7.3.2 Pacer Divisor Calculation. The number of analog samples per ARMOR frame for each analog channel must be evenly divisible into the number of bits per ARMOR frame. The initial bits per ARMOR frame are calculated to minimize the aggregate bit rate of the composite. Filler is then added to satisfy the divisibility rule to set the pacer clock speed. This step is referred to as the pacer divisor calculation since the pacer itself is derived from the same master oscillator as the aggregate bit rate clock.

6.7.3.3 ARMOR Channel Coding. Each input data channel is encoded into 8-, 12-, 16-, or 24-bit words, depending on the type of channel. The bit length of an ARMOR frame is always an integer multiple of eight, so 12-bit words must occur an even (multiple of two) number of times within each frame. The data within a frame is serially concatenated most significant bit first. Table 6-13, which is an example of an ARMOR frame with two analog, one parallel, four PCM, and one time code channel, is referenced in the following descriptions.

TABLE 6-13. SAMPLE ARMOR FRAME			
Frame Item	Description	Words/Frame	Bits/Word
Sync Pattern	X'FE6B2840'	1	32
Time Code Ch#1	Encoded Time	2	24
Time Code Ch #1	Encoded Time	1	16
Filler	X'FF'	7	8
PCM Ch#1	Encoded User Data	130	16
PCM Ch#2	Encoded User Data	162	16
PCM Ch#3	Encoded User Data	226	16
PCM Ch#4	Encoded User Data	321	16
Analog Ch #1	Encoded User Data	100	12
Analog Ch #2	Encoded User Data	20	12
Analog Ch #1	Encoded User Data	2	16
Analog Ch #1	Encoded User Data	260	8

6.7.3.4 Sync Pattern. All ARMOR frames begin with the fixed 32-bit sync pattern of hexadecimal FE6B2840.

6.7.3.5 Time Code Channels. When time code channels are present in an ARMOR multiplex, their data words always immediately follow the sync pattern or another time code channel. Time is encoded as 64 bits in two 24-bit words and one 16-bit word. [Table 6-14](#) defines the individual bits of the time code words. The encoded time is the time at the start of the ARMOR frame.

TABLE 6-14. TIME CODE WORD FORMAT			
BIT	WORD 1	WORD 2	WORD 3
22	D8	S6	
21	D7	S5	
20	D6	S4	
19	D5	S3	
18	D4	S2	
17	D3	S1	
16	D2	S0	
15	D1	SE	0
14	D0	NT	0
13	0	0	HN13
12	H5	0	HN12
11	H4	MS11	HN11
10	H3	MS10	HN10
9	H2	MS9	HN9
8	H1	MS8	HN8
7	H0	MS7	HN7
6	M6	MS6	HN6
5	M5	MS5	HN5
4	M4	MS4	HN4
3	M3	MS3	HN3
2	M2	MS2	HN2
1	M1	MS1	HN1
0	M0	MS0	HN0

LEGEND

D = Day of year.
H = Hour of day.
M = Minutes past the hour.
S = Seconds past the minute.
MS = Milliseconds past the second.
HN = Hundreds of nanoseconds past the millisecond.
SE = Sync error (time code decoding error).
NT = No time code (input signal detect fail).
0 = Always 0.

6.7.3.6 PCM Channels. User PCM data is encoded into 16-bit words. The number of 16-bit words (per channel) in each frame is approximately two percent greater than the number required to store the user data during the frame time period. These overhead words are included to compensate for minor variations in user data clock rates. In order to record the number of allocated frame bits that actually contain user data, the first two 16-bit words are redundant copies of a bit count. In [Table 6-13](#), PCM Channel #1 has 130 words: two count words and 128 data words. The bit count in either one of the redundant count words records the number of bits in the 128 data words that are actually user PCM data (most significant bit first). All remaining

bits are filler. The first user data bit in the most significant bit location of the third channel word (the first data word following the redundant count words) was the first bit to be received after the start of the ARMOR frame.

6.7.3.7 Analog Channels. Analog data is digitized into either 8-bit or 12-bit samples using offset binary notation (a sample of X'00' or X'000' is the largest negative value). No overhead words or bits are included with analog channel data because input sampling is synchronous to the start of the ARMOR frame. The first sample of each channel was captured at frame start time with all remaining samples evenly spaced throughout the frame time. Note that the location of the analog channel words within the composite ARMOR frame has no correlation with the time between the start and end of the frame when the analog samples were captured (digitized). The first sample of the 100 Analog Channel #1 words and the first sample of the 20 Analog Channel #2 words in Table [6-13](#) were both captured (digitized) at the same instant in time, which was the frame start time. Voice is a special case of an analog channel in that it is always 8-bit samples.

6.7.3.8 Parallel Channels. The encoding of parallel input channels is very similar to PCM encoding. Approximately two percent more than the minimum number of words necessary to store the user data during one ARMOR frame period are allocated to each parallel channel. The first two 16-bit words of each channel are redundant count words that record the actual number of allocated data words that contain user data. The remaining allocated words contain filler. Table [6-4](#) has two entries for Parallel Channel #1. The first entry shows the two (redundant) 16-bit count words and the second entry shows the number of allocated 8-bit data words for the channel. The number of 8-bit data words that contain user data is determined by examining either of the two count words. The first data word for each parallel channel was the first word received after the start of the ARMOR frame.

6.7.4 ARMOR Format Compatibility. Compatibility with the ARMOR format can be divided into two distinct cases. In the first case, the user is playing back a legacy tape (made with legacy multiplexer hardware and software) on non-legacy demultiplexer hardware and software. In the second case, the user is creating a tape on non-legacy multiplexer hardware and software for future playback by legacy demultiplexer hardware and software.

In the first case, the legacy tape contains a setup block (see paragraph [6.7.2](#)) at the start of the recording. The setup block contains the information necessary for the user to demultiplex the data records on the tape. The bit rate field in the setup block header section specifies the rate at which the legacy recording was generated. The saved scanlist field in the setup block trailer section specifies the exact sequence and size of the sync, data, and filler words in the recording.

In the second case, the user must first generate an ARMOR setup block at the start of the recording. Subsequent data records must then be formatted in accordance with the specification in the setup block. Setup block creation is described in [Appendix L](#).

6.7.5 ARMOR Format Validation. The CALCULEX, Inc. ARMOR Format Verification Program (AFVP) may be used to determine if an independently generated multiplex is compatible with existing legacy hardware. The AFVP reads the setup block from the data set under test and validates the data set frame structure (see paragraph [6.7.2](#)). Please refer to IRIG

Document 118, Test Methods For Telemetry Systems And Subsystems, Volume III, Test Methods For Recorder/Reproducer Systems And Magnetic Tape. The AFVP may be obtained from CALCULEX.¹⁰

6.8 Recorder Command and Control Mnemonics (CCM)

This section describes a set of standard commands and replies that can control tape, disk, and solid-state recorders. Not all commands may be applicable to all types of recorders or recorder implementations. Manufacturers who claim compliance with this Standard shall identify (in an Interface Control Document, for each recorder model) the specific command and reply subset that is implemented. An important aspect of the CCM standard is the required command-response protocol. For each command issued to a recorder, there shall be exactly one response from the recorder, and the response shall begin immediately upon conclusion of the command input. There shall be no delay between the receipt of the command at the recorder and the transmission of the reply by the recorder. Commands that initiate recorder functions requiring time to complete shall be replied to immediately, and the host shall poll the recorder status to determine when the function is complete. There shall be no unsolicited status output from the recorder, with one exception. This exception is a boot message upon leaving the POWER ON state, notifying the host that the recorder is ready to accept commands. The boot command shall contain a single asterisk as the last character. Thereafter, the recorder will only output in response to a command input. (A hardware reset or a software .RESET shall return the recorder to the POWER ON state.)

6.8.1 Command Summary. All commands must comply with the following syntax rules. The syntax rules are summarized as available commands in Table [6-15](#).

- a. All recorder commands are simple ASCII character strings delimited by spaces.
- b. All commands begin with an ASCII period (“.”) and, with the single exception of the .TMATS command, end with the first occurrence of a carriage return and line-feed terminator sequence.
- c. Parameters are separated from the commands and from each other with ASCII space characters.
- d. With one exception, command words and parameters may not include spaces. The one exception is the [text string] parameter for the .EVENT command.
- e. Multiple consecutive terminators and extraneous space characters are ignored.
- f. Each command is followed with either a text response, carriage return line feed, and an ASCII asterisk (“*”) response terminator or the asterisk response terminator only, indicating the recorder is ready for the next command.
- g. All numeric parameters, with one exception, are decimal numbers. The one exception is the [mask] parameter for the .CRITICAL command, which is hexadecimal.

¹⁰ Part Number 198007-0001 may be obtained from CALCULEX, Inc. P.O. Box 339, Las Cruces, NM 88004 (505) 525-0131 or by email request to info@calculex.com.

- h. Three commands, .FIND, .REPLAY, and .SHUTTLE, have numeric parameters that required units of measure. The [mode] parameter is used to specify the unit of measure (time, feet, or blocks.) If the [mode] parameter is omitted, the recorder shall use the most recently entered [mode].
- i. A [time] parameter value has five parts: days, hours, minutes, seconds, and milliseconds. Any part not entered defaults to zero except days, which defaults to don't care (current day). A period (".") identifies the start of the millisecond part, a hyphen ("-") separates the day from the hours, and colon characters (":") separate the hours, minutes, and seconds. The following are valid times: 123- (day only), 17 (hours only), 17:30 (hours and minutes), 17:30:05 (hours, minutes, seconds), 17:0:05 (hours, minutes, seconds), 17:30:05.232 (hours, minutes, seconds, milliseconds), 123-17 (day, hours), 123-17:30 (day, hours, minutes), etc.
- j. All commands begin with an ASCII period (".") and, with the single exception of the .TMATS command, end with a carriage return and line-feed terminator sequence.

TABLE 6-15. COMMAND SUMMARY

Command	Parameters[*]	Description
.ASSIGN	[destination-ID] [source-ID]	Assign replay (output) channels to source (input) channels
.BBLIST	{type}	Returns list of secured or unsecured bad blocks
.BBREAD	{block identifier}	Returns contents of specified block
.BBSECURE	{block identifier}	Marks an unsecured bad block as secure
.BIT		Runs all of the built-in-tests
.CRITICAL	[n [mask]]	Specify and view masks that determine which of the .HEALTH status bits are critical warnings
.DATE	[start-date]	Specify setting or displaying date from recording device
.DECLASSIFY		Secure erases the recording media
.DISMOUNT		Unloads the recording media
.DUB	[location]	Same as .PLAY but with internal clock
.ERASE		Erases the recording media
.EVENT	[text string]	Display event table or add event to event table
.FILES		Displays information about each recorded file
.FIND	[value [mode]]	Display current locations or find new play point
.HEALTH	[feature]	Display detailed status of the recorder system
.HELP		Displays table of "dot" commands
.IRIG106		Returns supported version number of IRIG-106 Recorder Command and Control Mnemonics
.LOOP		Starts record and play in read-after-write mode
.MEDIA		Displays media usage summary
.MOUNT		Powers and enables the recording media
.PAUSE		Pause current replay
.PLAY	[location][speed]	Reproduce recorded data of assigned output channels starting at [location] and at [speed]
.PUBLISH	[keyword] [parameter]	Configure, start and stop live data over the recorder Ethernet interface
.RECORD	[filename]	Starts a recording at the current end of data
.REPLAY	[endpoint [mode]]	Same as .SHUTTLE but with internal clock
.RESET		Perform software initiated system reset
.RESUME		Resume replay from pause condition
.SETUP	[n]	Displays or selects 1 of 16 (0...15) pre-programmed data recording formats
.SHUTTLE	[endpoint [mode]]	Play data repeatedly from current location to the specified endpoint location using external clock
.STATUS		Displays the current system status
.STOP	[mode]	Stops the current recording, playback, or both
.TIME	[start-time]	Displays or sets the internal system time
.TMATS	{mode} [n]	Write, Read, Save, or Get TMATS file
* Parameters in braces "{ }" are required. Parameters in brackets "[]" are optional. When optional parameters are nested ("[xxx [yy]]"), the outer parameter (xxx) must be specified in order to also specify the inner parameter (yy).		

6.8.2 Command Error Codes. Issuing invalid commands (bad syntax) or illegal commands (not accepted in the current system state) result in error code responses (with an ASCII “E” identifier) prior to the asterisk response terminator when a command cannot be completed. Table 6-16 shows possible error codes and the conditions under which they occur.

TABLE 6-16. COMMAND ERROR CODES		
Error	Description	Conditions
00	INVALID COMMAND	Command does not exist
01	INVALID PARAMETER	Parameter is out of range, or wrong alpha-numeric type
02	INVALID MODE	Command cannot be executed in the current state
03	NO MEDIA	Recording media is dismounted or not installed
04	MEDIA FULL	Command cannot be executed because there is no free space available on the recording media
05	COMMAND FAILED	Command failed to execute for any reason other than those listed above

Example:

```
.RECORD
E 03
*
```

6.8.3 Command Parameters and Responses. Each of the commands, command parameters, and recorder responses to the commands are described in the following sections.

6.8.3.1 .ASSIGN. The .ASSIGN [destination-ID] [source-ID] command shall be used for assigning replay (output) channels to source (input) channels. The source-IDs are composed from the channel type of the source as defined in Chapter 9 parameter “CDT” — a ‘-’ character and the sequence number of that type of channel (e.g., “PCMIN-3” for the 3rd PCM input channel). The destination-IDs are composed similarly – but with an “OUT” tag in the Channel Type, instead of an “IN” tag. Use keyword “NONE” in place of source-ID if a replay channel is to be unassigned. The command with the [destination-ID] parameter only should return the actually assigned source-ID; without any parameters it should return the full list of assignments.

Examples:

```
.ASSIGN PCMOUT-2 PCMIN-7
*
```

```
.ASSIGN PCMOUT-1 NONE
*
```

```
.ASSIGN PCMOUT-2
PCMIN-7
*
```



```
.ASSIGN
PCMOU-1 NONE
PCMOU-2 PCMIN-7
*
```

6.8.3.2 .BBLIST {*type*}: A .BBLIST command shall be utilized to return the unsecured bad block identifiers (any ASCII text, one identifier per line) from the media. A BBLIST command is only valid following a Declassify command. The *type* shall be provided indicating which type of bad block list is to be returned. If *type* = “unsecured” .BBLIST shall return a list of unsecured bad blocks. If *type* = “secured” .BBLIST shall return a list of secured bad blocks.

Example:

```
.BBLIST UNSECURED
1234
5678
:
fff
*
```

6.8.3.3 .BBREAD {*block identifier*}: A Bad Block Read command shall be utilized to return the raw data from the specified bad block in ASCII hexadecimal format. The *block identifier* shall be provided for the bad block to be read.

Example:

```
.BBREAD 5678
00040000
9E030000
:
2CE42CE4
*
```

6.8.3.4 .BBSECURE {*block identifier*}: A .BBSECURE command shall be utilized to mark an unsecured bad block as being secured. A block that has been identified as secured shall never be used for any subsequent data recording. Secured bad blocks shall be removed from unsecured bad block identifier list. The *block identifier* shall be provided for the block to be secured.

Example:

```
.BBSECURE 5678
*
```

6.8.3.5 .BIT. The .BIT command runs the built-in test (BIT) on the recorder. The prompt is returned immediately after the test is started. The .BIT command is only valid in the IDLE, ERROR, and FAIL states. During the BIT, the user must periodically check the status until the test is complete. While in BIT mode, the percent completion is shown with the .STATUS command. The result of the .BIT command is go/no-go status indicated by the end state. If the

system returns to the IDLE state, the BIT was successful. If the system goes to the FAIL state, the BIT failed and further system-specific diagnostics are required. The ASCII “S” in the response is the identifier of a .STATUS response.

Example:

```
.BIT
*
.STATUS
S 02 0 0 21%
*
.STATUS
S 02 0 0 74%
*
.STATUS
S 01 0 0
*
```

6.8.3.6 .CRITICAL [n [mask]]. The .CRITICAL command is used to view and specify the critical warning masks used with the .HEALTH command. An encoded 32-bit status word is displayed with the .HEALTH command for each feature as defined in .HEALTH command in the recorder. The .CRITICAL command allows the user to specify which status word bits constitute critical warnings. If a bit in the .CRITICAL mask word for a feature is set, then the corresponding .HEALTH status word bit for that feature signals a critical warning. The critical warning is turning the FAULT contact output indicator ON for a Chapter 10 compatible recorder.

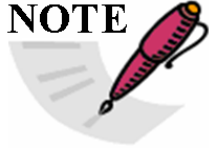
 <p>NOTE</p>	<p>Parameters in braces “{}” are required. Parameters in brackets “[]” are optional. When optional parameters are nested (“[xxx [yy]]”), the outer parameter (xxx) must be specified in order to also specify the inner parameter (yy).</p>
--	---

The .CRITICAL command without any parameters returns the mask word for each feature in ascending feature order. The .CRITICAL command with a single parameter (the feature number) returns the list of descriptive warning strings and status word bit associations for the specified feature. The .CRITICAL command with both the feature number parameter and the 8-character ASCII hexadecimal mask value parameter specifies a new mask value for the feature. All mask values in the command responses are hexadecimal.

 <p>NOTE</p>	<p>The critical warning is turning the FAULT contact output indicator ON for a Chapter 10 compatible recorder.</p>
--	--

Example #1: The command with no parameters returns the mask for each feature.

```
.CRITICAL
0 FFFFFFFF RECORDER
1 FFFFFFFF TIMEIN
2 000000FF ANAIN-1
3 0000006F PCMIN-1
4 0000000F PCMIN-2
  :
  :
15 00000010 1553IN-8
*
```

Example #2: The command with the feature number parameter only, no mask value, returns all of the possible warning text strings for the specified feature and shows which .HEALTH status word bit is associated with the particular warning.

```
.CRITICAL 4
4 00000004 PCMIN-2 Clock Error
4 00000008 PCMIN-2 Data Error
4 00000010 PCMIN-2 No Minor Frame Lock
4 00000020 PCMIN-2 No Major Frame Lock
*
```

Example #3: Entering both the feature number parameter and the mask value parameter resets the mask for the specified feature.

```
.CRITICAL 4 0000003C
4 0000003C PCMIN-2
*
```

6.8.3.7 .DATE. The .DATE [start-date] command displays or sets the internal systems date. The optional start-date parameter is formatted as shown in the example below. Without a parameter, this command displays the current system date. The timestamps recorded with user data are derived from this clock. The date shall be set in year-month-day format according to ISO 8601.

Example:

```
.DATE
DATE 2002-12-31
*
```

6.8.3.8 .DECLASSIFY. The .DECLASSIFY command erases all recorded data using an approved declassification procedure.



This command will permanently erase all recorded data. Data cannot be recovered once this command has been executed!

The prompt is returned immediately after the operation is started. During declassify, the user must periodically check the status until the operation is complete. While in DECLASSIFY state, the percent completion is shown with the .STATUS command.

Example:

```
.DECLASSIFY
*
.STATUS
S 04 0 0 23%
*
.STATUS
S 04 0 0 84%
*
.STATUS
S 01 0 0
*
```

6.8.3.9 .DISMOUNT. The .DISMOUNT command disables and, if necessary, removes power from the active recording media. The media may be removed only after this command is issued.

Example #1:

```
.DISMOUNT
*
```

Example #2: If a failure occurs, an error message is displayed before the prompt.

```
.DISMOUNT
E 03
*
```

6.8.3.10 .DUB [location]. The .DUB command is identical to the .PLAY command, except that it specifies the use of the internal playback clock to retrieve the recorded data.

6.8.3.11 .ERASE. The .ERASE command erases all data and resets the record point to the beginning of media (BOM).

	<p>This command will permanently erase all recorded data. Data cannot be recovered once this command has been executed!</p>
---	---

The prompt is returned immediately after the operation is started. During erase, the user must periodically check the status until the operation is complete. While in ERASE state, the percent completion is shown with the .STATUS command.

Example:

```
.ERASE
*
.STATUS
S 03 0 0 23%
*
.STATUS
S 03 0 0 84%
*
.STATUS
S 01 0 0
*
```

6.8.3.12 .EVENT [*text string*]. The .EVENT command adds an entry to the recorder event file or displays all of the current event file entries. If a non-blank text string is included with the command, a new event entry is appended to the event file with the text string in the message field of the event entry. The text string may be any length, but only the first 48 bytes, starting with the first non-blank character but including all subsequent blanks, are saved in the event file entry. If no text string is provided with the message, the current event file entries are displayed as a list of character strings showing the event sequence number, the absolute event time based on the recorder system time, the current media address (block number) at the time the event entry is created, and the optional text string.

Example:

```
.EVENT -
*
.EVENT This text was supplied with the .EVENT command
*
.EVENT x
*
.EVENT
1 001-00:13:58.109 101231 -
2 001-00:14:11.106 433213 This text was supplied with
the .EVENT command
3 001-17:44:06.677 2427654 x
*
```

6.8.3.13 .FILES. The .FILES command displays a list of character strings showing information about each recording session (file). Each string in the list contains the file number, file name, starting block number, file size in bytes, start day, and start time of the file. For those systems that also store the end day and time of each file, the end day and time may be added to the end of each file string. File names may not contain space or asterisk characters. If user names are not assigned to individual recordings, the default file names shall be “file1,” “file2,” etc. Each file

string shall be formatted as shown in the following example (with optional end day and end time).

Example:

.FILES (File name unused byte positions omitted)

```

1  TPD-10  10000  272760832  001-00:13:58.109  001-
      00:14:03.826
2  TPD-11  92884  425984000  001-00:14:11.106  001-
      00:14:28.602
3  file3   350790 305430528  123-17:44:06.677  123-
      17:44:13.415
*
```

6.8.3.14 **.FIND** [*value* [*mode*]]. The **.FIND** command is used to report the current record and play point or to set the play point to the desired location within the recorded data. The desired location can be expressed in a number of different formats or “modes:” time, blocks, and feet. When the command is entered without any parameters, the recorder returns the current record point and current play points, using the current default mode. The default mode is declared each time a mode parameter is supplied with the **.FIND** command, the **.REPLAY** command, or the **.SHUTTLE** command. Thereafter, the mode parameter may be omitted and the recorder will use the default mode. The mode keywords are TIME, BLOCKS, and FEET.

The location specified in the value parameter of the **.FIND** command can be numeric or one of six keywords: BOM (beginning of media), BOD (beginning of data), EOD (end of data), EOM (end of media), BOF (beginning of file), and EOF (end of file.) These keywords may be used with or without a mode parameter. Numeric location values, whether accompanied by the mode keyword or not, must be valid for the specified or default mode. Blocks and feet are entered as decimal integer numbers. Time is entered as specified in paragraph [6.8.1 item i](#).

Example #1: Display the current record point and play point. The default mode is blocks.

```

.FIND
F 1022312 BOD
*
```

Example #2: Find a specific time in the recorded data.

```

.FIND 15:33:12 TIME
*
.STATUS
S 08 0 0 41%
*
.STATUS
S 08 0 0 84%
*
```

```

.STATUS
S 01 0 0
*
.FIND
F 102-16:18:27.000 102-15:33:12.000
*
```

6.8.3.15 **.HEALTH** [*feature*]. The **.HEALTH** command provides a standard mechanism for status information to be conveyed to the user. The *feature* parameter is defined as 0 for recorder status, and for each data source it is the decimal reference of the Channel ID specified by the “TK1” parameter for the corresponding data source by the TMATS setup. Entering the command without the optional parameter displays a list of encoded status word for each feature. Entering a decimal feature number parameter with the command decodes the status word for a single feature and displays a list of messages pertaining to the feature, one for each set bit in the status word; see Table [6-17](#) for recommended usage of the status bits. This standard requires that the syntax of the responses to the **.HEALTH** command conform to the following rules:

- a. If no data sources are implemented, the response to a **.HEALTH** command is the recorder status only.
- b. In addition to the feature number the command should return a description of the corresponding channel type, composed from the channel type of the source as defined in Chapter 9 parameter “CDT” — a ‘-’ character and the sequence number of that type of channel (e.g., “PCMIN-3” for the 3rd PCM input channel).
- c. The description of a feature may not contain an asterisk character.
- d. The feature list response (no feature number parameter supplied with the command) is a sequence of text strings, each containing the decimal feature number, the 8-character ASCII hexadecimal representation of the 32-bit status word for the feature, a text feature description, and a carriage return and line feed terminator. The value of the 32-bit status word for a “healthy” feature shall be all zeros. If a feature is disabled, the 8-character ASCII hexadecimal string shall be replaced with eight ASCII hyphen “-” characters.
- e. The individual feature response (feature number parameter supplied with the command) is a sequence of descriptive text strings, one for each set bit in the feature status word. Each string is terminated with a carriage return and line feed.
- f. The critical bits should be cleared when they are reported by a **.HEALTH** command.

The **.CRITICAL** command is used to specify and view the mask word for each feature that determines if a set **.HEALTH** status word bit adds to the total non-critical or critical warning counts displayed with the **.STATUS** command.

TABLE 6-17. USE OF STATUS BITS

Feature	Bit	Mask (Hex)	Description
Recorder	0	01	BIT Failure
	1	02	Setup Failure
	2	04	Operation Failure
	3	08	Media Busy Unable to Accept Command
	4	10	No Media
	5	20	Media I/O Failure
	6	40	Media Almost Full
	7	80	Media Full
	31-8		Vendor-Specific Health Status Bits
Time Code	0	01	BIT Failure
	1	02	Setup Failure
	2	04	No External Signal
	3	08	Bad External Signal
	4	10	Synchronize Failure
	5	20	Reserved for future Chapter 10 status bit
	6	40	Reserved for future Chapter 10 status bit
	7	80	Reserved for future Chapter 10 status bit
	31-8		Vendor-Specific Health Status Bits
PCM	0	01	BIT Failure
	1	02	Setup Failure
	2	04	Bad Clock Failure
	3	08	Bad Data Failure
	4	10	Minor Frame Sync Failure
	5	20	Major Frame Sync Failure
	6	40	Bit Sync Lock Failure
	7	80	Watch Word Failure
	31-8		Vendor-Specific Health Status Bits
1553	0	01	BIT Failure
	1	02	Setup Failure
	2	04	Response Timeout Error
	3	08	Format Error
	4	10	Sync Type or Invalid Word Error
	5	20	Word Count Error
	6	40	Reserved for future Chapter 10 status bit
	7	80	Watch Word Failure
	31-8		Vendor-Specific Health Status Bits

Table 6-17 Use Of Status Bits (Continued)			
Feature	Bit	Mask (Hex)	Description
Video	0	01	BIT Failure
	1	02	Setup Failure
	2	04	No Video Signal Error
	3	08	Bad Video Signal Error
	4	10	No Audio Signal Error
	5	20	Bad Audio Signal Error
	6	40	Reserved for future Chapter 10 status bit
	7	80	Reserved for future Chapter 10 status bit
	31-8		Vendor-Specific Health Status Bits
Analog	0	01	BIT Failure
	1	02	Setup Failure
	2	04	No Analog Signal Error
	3	08	Bad Analog Signal Error
	4	10	Reserved for future Chapter 10 status bit
	5	20	Reserved for future Chapter 10 status bit
	6	40	Reserved for future Chapter 10 status bit
	7	80	Reserved for future Chapter 10 status bit
	31-8		Vendor-Specific Health Status Bits
Image or Message	0	01	BIT Failure
	1	02	Setup Failure
	2	04	Bad Signal Error
	3	08	Data Content Error
	4	10	Reserved for future Chapter 10 status bit
	5	20	Reserved for future Chapter 10 status bit
	6	40	Reserved for future Chapter 10 status bit
	7	80	Reserved for future Chapter 10 status bit
	31-8		Vendor-Specific Health Status Bits
Other Types	0	01	BIT Failure
	1	02	Setup Failure
	2	04	Bad Signal Error
	3	08	Data Content Error
	4	10	Reserved for future Chapter 10 status bit
	5	20	Reserved for future Chapter 10 status bit
	6	40	Reserved for future Chapter 10 status bit
	7	80	Reserved for future Chapter 10 status bit
	31-8		Vendor-Specific Health Status Bits

Example #1:

```

.HEALTH
0 00000000 SYSTEM
1 00000000 TIMEIN
2 00000000 ANAIN-1
3 ----- PCMIN-1
4 00000034 PCMIN-2
  :
15 00000000 1553IN-8

```

Example #2:

```

*.HEALTH 4
4 00000004 PCMIN-2 Clock Error
4 00000010 PCMIN-2 No Minor Frame Lock
4 00000020 PCMIN-2 No Major Frame Lock
*

```

6.8.3.16 .HELP. The .HELP command displays a list showing a summary of the serial "dot" commands and parameters supported by the system.

Example:

```

.HELP
.ASSIGN
.BBLIST
.BBREAD block identifier
.BBSECURE block identifier
.BIT
.CRITICAL [n [mask]]
.DATE
.DECLASSIFY
.DISMOUNT
.DUB [location]
.ERASE
.EVENT [message]
.FILES
.FIND [value [mode]]
.HEALTH [feature]
.HELP
.IRIG106
.LOOP
.MEDIA
.MOUNT
.PAUSE
.PLAY [location][speed]
.PUBLISH
.RECORD [filename]
.REPLAY [endpoint [mode]]

```

Example is continued on next page

```
.RESET
.RESUME
.SETUP [n]
.SHUTTLE [endpoint [mode]]
.STATUS
.STOP [mode]
.TIME [start-time]
.TMATS {mode} [n]
*
```

6.8.3.17 .IRIG106. The `.IRIG106` command returns the release version number of the IRIG-106 Chapter 6 Recorder Command and Control Mnemonics that the recorder is supporting. Because this command was introduced in IRIG-106-07, recorders supporting earlier releases should answer this command with “E00” error message (invalid command).

Example: The recorder CCM compatible with IRIG106-07.

```
.IRIG106
7
*
```

6.8.3.18 .LOOP. The `.LOOP` command is used to put the recorder into read-after-write mode, recording and simultaneously playing back the recorded data. The replayed data is read back from the recording media. If the recorder is already recording when the `.LOOP` command is issued, the command starts the playback at the current record point without affecting the recording.

Example:

```
.STATUS
S 01 0 0
*
.LOOP
*
.STATUS
S 07 0 0 35%
*
```

6.8.3.19 .MEDIA. The `.MEDIA` command displays the media usage summary. It shows the number of bytes per block, the number of blocks used, and the number of blocks remaining, respectively.

Example:

```
.MEDIA
MEDIA 32768 1065349 6756127
*
```

6.8.3.20 .MOUNT. The .MOUNT command applies power and enables the device for recording. For systems with multiple memory canisters or media cartridges, the effect of the .MOUNT command on each canister or media cartridge is defined in advance with vendor-specific commands.

Example:

```
.MOUNT
*
```

6.8.3.21 .PAUSE. The .PAUSE command stops the replay operation. If parallel recording is being performed, it continues. If no play position is moved in between, the .RESUME command can be used to continue replay. The .PAUSE can also be used to stop only the replay while the recording continues (in this case, a new replay should be started with a new .PLAY command).

6.8.3.22 .PLAY [location] [speed]. The .PLAY command starts a playback of the data at either the current play point or at the location specified in the optional parameter with the command. The current play point is defined to be the media location immediately following the most recently played data. If no .PLAY command has been issued since recorder power-on, the current play point is the beginning of data. The location parameter has two forms, which are [block_number] and [filename [block_offset]]. If the first character of the location parameter is numeric, the entire parameter must be numeric, specifying the block number address at which to start the playback. When the first character of the location parameter is alphabetic, the parameter is the filename to playback. It may have a second, optional parameter specifying the numeric 0-origin block offset into the named file. To begin playing at a location other than a block number or file, use the .FIND command allows positioning of the play point to the desired location. The optional [speed] parameter specifies the replay speed, if other than real time replay speed is required. The syntax of the speed specification is: *N or /N (e.g., *5 for 5 times faster, /8 for 8 times slower replay).

Example: Replay from the current position 4 times faster than real-time speed.

```
.PLAY file1 250
*
.PLAY *4
*
```

6.8.3.23 .PUBLISH keyword [parameter]. The .PUBLISH command shall be utilized for configuring, starting, and stopping UDP uni-, multi-, or broadcast of live data in IRIG106 Chapter 10 section 10.6 packet format over any IP interface to the recorder. The following keywords are allowed:

```
.PUBLISH START IPaddress PortAddress Channel-ID-List
  (Start the streaming of the specified channel IDs to the destination address)
.PUBLISH STOP Channel ID-List
  (Stop streaming of the specified channel IDs)
```

The *IPaddress PortAddress* parameter defines the destination IP address and the port number of the UDP broadcast.

The *Channel-ID-List* parameter can be:

- The keyword “ALL” means all available Channel ID
- The decimal representation of one single Channel ID IAW IRIG106 Chapter 10 Section 10.6.1.1.b
- A range of Channel ID groups connected together by ‘-’ character, it select all channels within the specified range
- More than one Channel Id or Channel ID group separated by white space (e.g. ‘ ’) characters

The .PUBLISH command without any parameter returns the streaming Channel IDs and their destinations.

Examples:

```
.PUBLISH START 192.145.255.255 1234 ALL  
*
```

```
.PUBLISH START ::FFFF:C091:FFFF 1234 ALL  
*
```

```
.PUBLISH  
192.145.255.255 1234 ALL  
*
```

```
.PUBLISH STOP ALL  
*
```

```
.PUBLISH START 192.145.255.255 1234 1-12 18  
*
```

```
.PUBLISH START 192.146.255.255 2345 13-17  
*
```

```
.PUBLISH  
192.145.255.255 1234 1-12 18  
192.146.255.255 2345 13-17  
*
```

6.8.3.24 .RECORD [*filename*]. The .RECORD command starts a new recording. The optional file name parameter is an ASCII string with up to eleven characters, beginning with an alphabetic character, and with no spaces or asterisks. If the file name parameter is omitted, the filename will be of the form “file*n*,” where *n* is the file number. The recording will continue until the recording media is full or until the .STOP command is issued.

Example:

```
.RECORD
*
```

6.8.3.25 .REPLAY [*endpoint* [*mode*]]. The .REPLAY command is identical to the .SHUTTLE command, except that it specifies that the internal clock is to be used to retrieve the data.

6.8.3.26 .RESET. The .RESET command performs a software initiated reset of the recorder, returning the recorder to the power-on state.

Example:

```
.RESET
*
```

6.8.3.27 .RESUME. The .RESUME command can be used to continue the replay from the location where it was stopped by the .PAUSE operation — with the replay speed specified at the last .PLAY command. If the play position was moved with the .FIND command since the .PAUSE command was used, the replay cannot be continued by the .RESUME command - a new .PLAY command should be issued.

6.8.3.28 .SETUP [*n*]. The .SETUP command chooses one of 16 pre-defined setups stored in the recorder. The optional parameter is a one or two digit decimal setup number from 0 to 15. The current setup may be displayed by omitting the setup number parameter.

Example #1: Including the setup number changes the setting.

```
.SETUP 5
SETUP 5
*
```

Example #2:

```
.SETUP
SETUP 10
*
```

6.8.3.29 **.SHUTTLE** [*endpoint* [*mode*]]. The **.SHUTTLE** command initiates a repeated playback from the current play point to the end point specified in the command, using an external clock to retrieve the data. The syntax of the endpoint parameter is identical to that of the **.FIND** command.

Example:

```
.SHUTTLE 1430 FEET
*
```

6.8.3.30 **.STATUS**. The **.STATUS** command displays the current state of the recorder and two counts. The first is the total number of non-critical warning bits currently set and the second is the total number of critical warning bits currently set. If the recorder is in any state other than **FAIL**, **IDLE**, **BUSY**, or **ERROR**, the command also displays a progress percentage, the meaning of which is dependent on the specific state. Whenever the recorder is transitioning between states and the transition is not instantaneous, the **.STATUS** command will return the **BUSY** state. The **ERROR** state is entered when the currently executing command does not complete successfully. For example, when a **.FIND** command is unable to locate the specified position on the media, the recorder transitions to the **ERROR** state. Table 6-18 shows the various states by numerical code and describes the meaning of the progress percentage for each state. An ASCII “S” character identifies a **.STATUS** command response.

TABLE 6-18. RECORDER STATES		
State Code	State Name	Progress Description
00	FAIL	---
01	IDLE	---
02	BIT	Percent complete
03	ERASE	Percent complete
04	DECLASSIFY	Percent complete
05	RECORD	Percent media recorded
06	PLAY	Percent recording played
07	RECORD & PLAY	Percent media recorded
08	FIND	Percent complete
09	BUSY	---
10	ERROR	---

Example #1:

```
.STATUS
S 03 0 0 84%
*
```

Example #2: States that do not have a progress indication omit that field in the response.

```
.STATUS
S 01 0 0
*
```

6.8.3.31 .STOP [mode]. The .STOP command stops a recording, playback, or both. The optional mode parameter may be either the word RECORD or the word PLAY. If the optional mode parameter is not specified, both recording and playing (or either of the two modes if the other is not active) will be stopped. Using the parameter enables either recording or playing to be stopped without affecting the other, when both are active.

Example #1:

```
.STOP
*
```

Example #2: The current state can be displayed with the status command.

```
.STATUS
S 07 0 0 26%
*
.STOP PLAY
*
.STATUS
S 05 0 0 26%
*
```

Example #3: The .STOP command returns an error if the recorder is not in the appropriate state.

```
.STATUS
S 01 0 0
*
.STOP
E 02
*
```

6.8.3.32 .TIME [start-time]. The .TIME command displays or sets the internal systems time. The optional start-time parameter is formatted as shown in the example below. Without a parameter, this command displays the current system time.

Example #1:

```
.TIME
TIME 001-23:59:59.123
*
```

Example #2: To set the time, enter a value expressed in days, hours, minutes, seconds and milliseconds.

```
.TIME 123-13:01:35
TIME 123-13:01:35.000
*
```

Examples #3-5: Trailing values and punctuation may be omitted (zero is default).

Example #3:

```
.TIME 123-
TIME 123-00:00:00.000
*
```

Example #4:

```
.TIME 15:31
TIME 000-15:31:00.000
*
```

Example #5:

```
.TIME 15:31:20
TIME 000-15:31:20.000
*
```

6.8.3.33 .TMATS {mode} [n]. The .TMATS command provides a vendor-independent mechanism for loading a setup file into the recorder and retrieving a setup file from the recorder. The required mode parameter must be one of the following four words: WRITE, READ, SAVE, or GET. Writing or reading a TMATS file transfers the file between the external host and the recorder's internal volatile memory buffer. Saving or getting a TMATS file transfers the file between the recorder's internal volatile memory buffer and the recorder's internal non-volatile setup file storage area. To store a new setup file in the recorder, the .TMATS WRITE command is first used to transfer the file to the recorder, followed by a .TMATS SAVE [n] command to store the file in non-volatile memory. The numeric setup file number parameter is not valid with the .TMATS WRITE command. When saving the file to non-volatile memory, the optional setup file number parameter may be entered to designate a specific setup number (see the

.SETUP command.) If the setup file number parameter is not specified with the .TMATS SAVE command, the file number defaults to setup 0. The .TMATS GET [n] command performs the inverse of the .TMATS SAVE command, retrieving the specified or default (0) file from non-volatile to volatile memory within the recorder. The .TMATS READ command transfers the file currently in the recorder's volatile setup file buffer to the host.

Termination of the .TMATS WRITE command string is unique. All other command strings terminate with the first occurrence of a carriage return and line feed sequence. The .TMATS WRITE command string does not terminate until the occurrence of a carriage return and line feed pair followed by the word END and another carriage return and line feed pair.

Example #1: The .TMATS WRITE command includes the TMATS file followed by the word END.

```
.TMATS WRITE
G\DSI\N=18;
G\DSI-1:TimeInChan1;
G\DSI-2:VoiceInChan1;
G\DSI-3:1553Chan01;
      :
      :
P-8\IDC8-1:0;
P-8\ISF2-1:ID;
P-8\IDC5-1:M;
END
*
```

Example #2: The .TMATS READ command returns the file currently in the volatile buffer.

```
.TMATS READ
G\DSI\N=18;
G\DSI-1:TimeInChan1;
G\DSI-2:VoiceInChan1;
G\DSI-3:1553Chan01;
      :
      :
P-8\IDC8-1:0;
P-8\ISF2-1:ID;
P-8\IDC5-1:M;
*
```

Example #3: The .TMATS SAVE command stores the file in the volatile buffer to the designated non-volatile file memory in the recorder.

```
.TMATS SAVE 3
*
```

Example #4: The .TMATS GET command retrieves the designated file from non-volatile file memory in the recorder and puts it in a buffer that can be read by the user.

.TMATS GET 3

*

6.8.5 Command Validity Matrix. [Table 6-19](#) identifies the recorder states in which each of the serial commands is valid. The legend at the bottom of the table explains the matrix entry codes. Two codes, 3 and 4, identify states in which the associated command may or may not be valid due to system-specific implementation. Recorder users should assume that a command is not supported in a system-specific state (code 3 or 4) unless the specific recorder's Interface Control Document assures that support is provided.

6.8.6 Required Command Subset. [Table 6-20](#) identifies the minimum subset of commands that must be implemented for each recorder type to be compliant with this standard.

TABLE 6-19. COMMAND VALIDITY MATRIX

STATE COMMAND	BUILT-IN TEST	BUSY	DECLASSIFY	ERASE	ERROR	FAIL	FIND	IDLE	PLAY	POWER ON	RECORD	RECORD & PLAY
.ASSIGN					X	X		X			X	
.BBLIST								6				
.BBREAD								6				
.BBSECURE								6				
.BIT					X	X		X				
.CRITICAL	1		1	1	1	1	1	1	1		1	1
.DATE	1		1	1	1	1	1	1	1		1	1
.DECLASSIFY					X			X				
.DISMOUNT					2			2				
.DUB					X			X			X	
.ERASE					X			X				
.EVENT	3				3	3	3	3	3		3	3
.FILES	X				X	X	X	X	X		X	X
.FIND					X			X			X	
.HEALTH	X		X	X	X	X	X	X	X		X	X
.HELP	X		X	X	X	X	X	X	X		X	X
.IRIG106	X	X	X	X	X	X	X	X	X		X	X
.LOOP					X			X			X	
.MEDIA	X				X	X	X	X	X		X	X
.MOUNT					2			2				
.PAUSE					X			X			4	
.PLAY					X			X			4	
.PUBLISH					5			5	5		5	5
.RECORD					X		4	X	4			
.REPLAY					X			X			X	
.RESET	X	X	X	X	X	X	X	X	X		X	X
.RESUME					X			X			4	
.SETUP	1		1	1	1	1	1	1	1		1	1
.SHUTTLE					X			X			X	
.STATUS	X	X	X	X	X	X	X	X	X		X	X
.STOP							X		X		X	X
.TIME	1		1	1	1	1	1	1	1		1	1
.TMATS					X			X				

Legend

X= Always valid.
1 = Query function always valid. Changing masks, setup, or time only valid in IDLE or ERROR.
2 = MOUNT and DISMOUNT only valid if not mounted or dismounted, respectively.
3 = Query always valid. Declaring always valid in record, but not recording is system-specific.
4 = Simultaneous recording and playing is system-specific.
5 = Simultaneous recording, playing and publishing is system-specific.
6 = Only valid after declassify command execution has completed

TABLE 6-20. REQUIRED COMMANDS			
Command	Recorder Type		
	Tape	Solid State	Disk
.ASSIGN	O	O	O
.BBLIST	O	O	O
.BBREAD	O	O	O
.BBSECURE	O	O	O
.BIT	M	M	M
.CRITICAL	M	M	M
.DATE	M	M	M
.DECLASSIFY	O	M	O
.DISMOUNT	M	M	M
.DUB	O	O	O
.ERASE	M	M	M
.EVENT	O	O	O
.FILES	O	M	M
.FIND	O	O	O
.HEALTH	M	M	M
.HELP	M	M	M
.IRIG106	M	M	M
.LOOP	O	O	O
.MEDIA	M	M	M
.MOUNT	M	M	M
.PAUSE	O	O	O
.PLAY	O	O	O
.PUBLISH	O	O	O
.RECORD	M	M	M
.REPLAY	O	O	O
.RESET	M	M	M
.RESUME	O	O	O
.SETUP	M	M	M
.SHUTTLE	O	O	O
.STATUS	M	M	M
.STOP	M	M	M
.TIME	M	M	M
.TMATS	M	M	M
Legend			
M = Mandatory		O = Optional	